

Service Manual

Audio Mixer

Mixer

SH-DJ1200

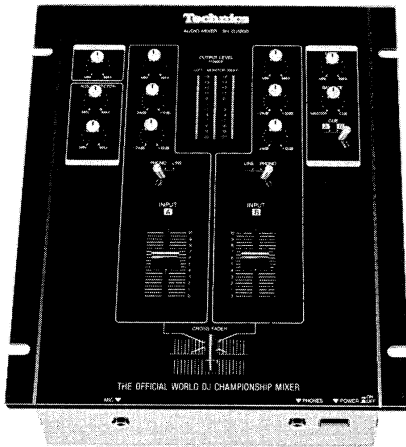

Colour

(K) Black Type

Area

Suffix for Model No.	Area	Colour
(PP)	U.S.A. and Canada.	(K)
(E)	Europe.	
(EB)	Great Britain.	
(GU)	Asia, Latin America, Middle Near East and Africa.	
(GN)	Oceania.	

■ Specifications

■ Input sensitivity/input impedance

PHONO	1.5 to 15 mV/47k Ω
LINE	100 to 1000mV/more than 10k Ω
AUX/EFFECTOR	150 mV/47k Ω
MIC	0.7 mV/1k Ω

■ Rated output voltage

LINE	1V/600 Ω
MONITOR	2V/2.2k Ω
PHONES	1.5V/100 Ω (Load 100 Ω)
REC	1V/2.2k Ω

■ Maximum output voltage

(10k Ω load excluding headphones)	
LINE	8V
MONITOR	8V (headphones open)
PHONES	1.5V (Load 100 Ω)
REC	8V

■ Applicable load impedance

LINE	More than 600 Ω
MONITOR	More than 10k Ω
PHONES	More than 47 Ω
REC	More than 10k Ω

■ Residual hum and noise

Less than 0.2 mV

■ Frequency response

PHONO	30 Hz to 15 kHz (RIAA \pm 1 dB)
LINE	10 Hz to 70 kHz (- 3dB)
AUX/EFFECTOR	10 Hz to 100 kHz (- 3dB)
MIC	100 Hz to 15 kHz (- 3dB)

■ Tone control characteristics

	12 dB/oct
LOW	+12dB, - 24dB (63Hz)
HIGH	+12dB, - 24dB (10kHz)

■ General

Power supply:	
For (PP) area;	AC 60 Hz, 120V
For (E, EB, GU, GN) areas;	AC 50/60 Hz, 230 - 240V
Power consumption	15W
Dimensions	260 \times 102 \times 305 mm
(W \times H \times D)	(10 ¹⁵ / ₆₄ " \times 4 ¹ / ₆₄ " \times 12 ¹ / ₆₄ ")
Weight	3.4 kg (7.5 lb.)

Note:

Design and specifications are subject to change without notice.
Weight and dimensions are approximate.

⚠ WARNING

This service information is designed for experienced repair technicians only and is not designed for use by the general public. It does not contain warnings or cautions to advise non-technical individuals of potential dangers in attempting to service a product. Products powered by electricity should be serviced or repaired only by experienced professional technicians. Any attempt to service or repair the product or products dealt with in this service information by anyone else could result in serious injury or death.

Technics®

© 1996 Matsushita Electric Industrial Co., Ltd.
All rights reserved. Unauthorized copying and distribution is a violation of law.

■ Contents

	Page		Page
Safety Precaution	2	Operation Checks and Component	
Accessories	2	Replacement Procedures	12 ~ 15
Caution for AC Mains Lead	3	Schematic Diagram	16 ~ 21
Features	4	Block Diagram	22
Connections	4 ~ 7	Printed Circuit Boards	23 ~ 27
Name of the Parts	8, 9	Terminal Guide of IC's Transistors and Diodes	27
Proper Use of the SH-DJ1200	9	Wiring Connection Diagram	28
Audio Mixer Slide Volume Control		Replacement Parts List	29, 30, 32, 33, 35
Replacement Instructions	10	Cabinet Parts Location	31
Troubleshooting Guide	11	Packaging	34

■ Safety Precaution (This "Safety Precaution" is applied only in U.S.A.)

1. Before servicing, unplug the power cord to prevent an electric shock.
2. When replacing parts, use only manufacturer's recommended components for safety.
3. Check the condition of the power cord. Replace if wear or damage is evident.
4. After servicing, be sure to restore the lead dress, insulation barriers, insulation papers, shields, etc.
5. Before returning the serviced equipment to the customer, be sure to make the following insulation resistance test to prevent the customer from being exposed to a shock hazard.

● INSULATION RESISTANCE TEST

1. Unplug the power cord and short the two prongs of the plug with a jumper wire.
2. Turn on the power switch.
3. Measure the resistance value with ohmmeter between the jumpered AC plug and each exposed metal cabinet part, such as screwheads antenna, control shafts, handle brackets, etc. Equipment with antenna terminals should read between 3 MΩ and 5.2 MΩ to all exposed parts. (Fig. A)
Equipment without antenna terminals should read approximately infinity to all exposed parts. (Fig. B)

Note: Some exposed parts may be isolated from the chassis by design. These will read infinity.

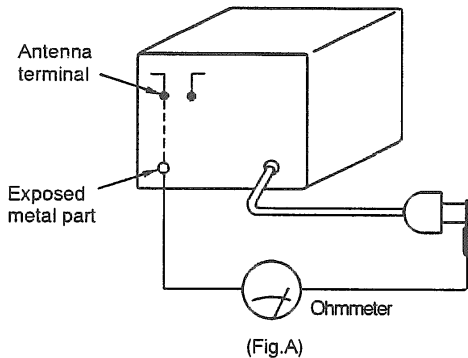

Resistance = 3 MΩ — 5.2 MΩ

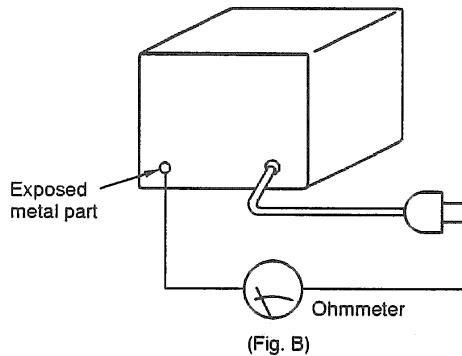

Resistance = Approx. ∞

4. If the measurement is outside the specified limits, there is a possibility of a shock hazard. The equipment should be repaired and rechecked before it is returned to the customer.

■ Accessories

● AC power cord

(PP) area: (SJA172)1pc.

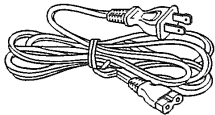

(EB) area: (VJA0733)1pc.

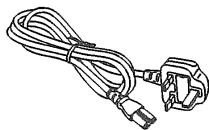

(E, GU) areas: (RJA0019-2K)1pc.

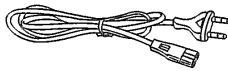

(GN) area: (RJA0035-K)1pc.

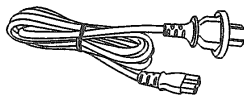

● Power plug adaptor

(GU) area: (SJP5213-2)1pc.

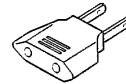

● Sticker

(RFE0032) :1pc.



■ Caution for AC Mains Lead

(“EB” area code model only)

For your safety, please read the following text carefully.

This appliance is supplied with a moulded three pin mains plug for your safety and convenience.

A 5-ampere fuse is fitted in this plug.

Should the fuse need to be replaced please ensure that the replacement fuse has a rating of 5-ampere and that it is approved by ASTA or BSI to BS1362.

Check for the ASTA mark  or the BSI mark  on the body of the fuse.

If the plug contains a removable fuse cover you must ensure that it is refitted when the fuse is replaced.

If you lose the fuse cover the plug must not be used until a replacement cover is obtained.

A replacement fuse cover can be purchased from your local dealer.

CAUTION!

IF THE FITTED MOULDED PLUG IS UNSUITABLE FOR THE SOCKET OUTLET IN YOUR HOME THEN THE FUSE SHOULD BE REMOVED AND THE PLUG CUT OFF AND DISPOSED OF SAFELY.

THERE IS A DANGER OF SEVERE ELECTRICAL SHOCK IF THE CUT OFF PLUG IS INSERTED INTO ANY 13-AMPERE SOCKET.

If a new plug is to be fitted please observe the wiring code as shown below.

If in any doubt please consult a qualified electrician.

IMPORTANT

The wires in this mains lead are coloured in accordance with the following code:

Blue: Neutral, Brown: Live.

As these colours may not correspond with the coloured markings identifying the terminals in your plug, proceed as follows:

The wire which is coloured Blue must be connected to the terminal which is marked with the letter N or coloured Black or Blue.

The wire which is coloured Brown must be connected to the terminal which is marked with the letter L or coloured Brown or Red.

WARNING: DO NOT CONNECT EITHER WIRE TO THE EARTH TERMINAL WHICH IS MARKED WITH THE LETTER E, BY THE EARTH SYMBOL \perp OR COLOURED GREEN OR GREEN/YELLOW.

THIS PLUG IS NOT WATERPROOF—KEEP DRY.

Before use

Remove the connector cover.

How to replace the fuse

The location of the fuse differ according to the type of AC mains plug (figures A and B). Confirm the AC mains plug fitted and follow the instructions below.

Illustrations may differ from actual AC mains plug.

1. Open the fuse cover with a screwdriver.

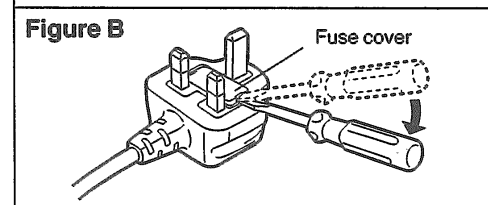
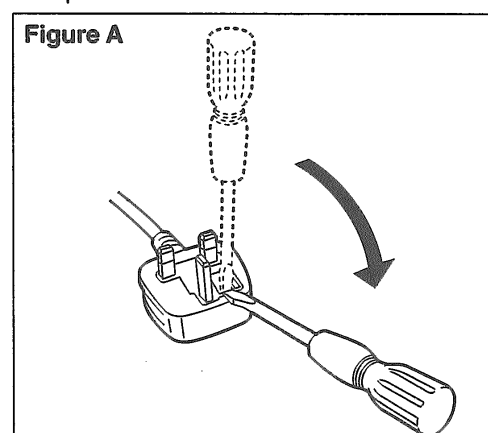

2. Replace the fuse and close or attach the fuse cover.

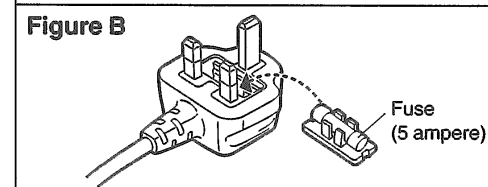
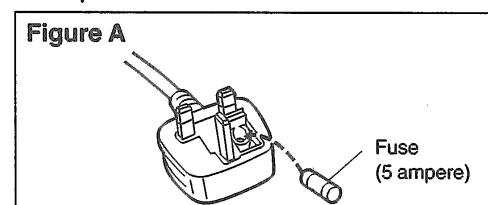

■ Features

This model is the official audio mixer for the DMC-sponsored World DJ Championship to be held each year in 1997 and beyond. The event will bring together professional disc jockeys from all over the world to compete for top honors.

It is a top-of-the-line audio mixer with the kind of outstanding design, functions and sound quality that suits the requirements of disc jockeys accustomed to giving scratch-mixing performances in a variety of different ways.

Operating ease

- This audio mixer is designed with the same height as that of the SL-1200MK2 for operating ease.
- By providing adequate space in the panel layout around the channel faders and cross fader and by eliminating the protruding parts, full rein can be given to individual technique which exactly reflects the mood of the moment even when it comes to high-powered scratch-mixing.

Functions

- The model comes with both high and low equalizers so that all manner of sound sources can be accommodated to generate a highly creative style of sound. A wide margin of creativity in producing sound is provided since the attenuation is set to a high -24 dB (12 dB/oct).

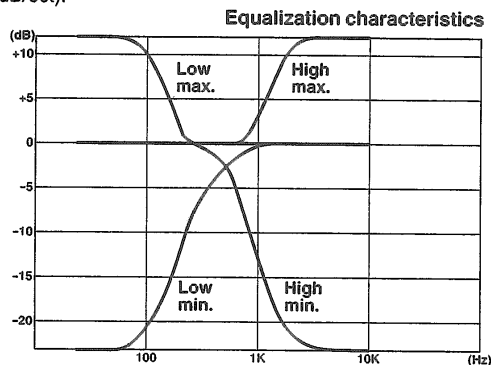

- The model is equipped with TRIM controls (± 10 dB) which compensate for differences in the source level.
- By adding a pre-fader monitor, the channels selected by the CUE controls can be monitored regardless of the positions of the faders. It is also possible to mix and monitor the line-out sources.
- The model comes with line-out connectors for monitoring so that sound can be monitored not only with headphones but through the speakers inside the booth.
- The line-out source L and R levels as well as the monitor source levels can be checked out on the 12-point, 3-column level meter.
- An AUX IN connector is provided to enable a sampler, keyboard, etc. to become part of the disc jockey scene.

Construction and materials

- New 45 mm stroke faders with an excellent durability and smooth operating touch have been developed for this model. The service life of the channel faders and cross fader has been improved by a quantum leap (an approximately 10-fold increase over existing models; nominal service life: 100,000 operations).
- A spare channel fader and a spare cross fader have been provided on the back panel just in case, and the faders themselves are designed to enable easy replacement.
- Lever switches are employed for the input selector controls (LINE, PHONO) and, by providing adequate space around them, they can also be used for operations involving the transformer scratch function.
- The panels are made of aluminum, and the surfaces have a glossy finish with a tough black coating which makes it hard for the markings to be worn away.

What is DMC?

DMC is the world's largest disc jockey organization whose members include the world's top disc jockeys, musicians and producers. Its objective is to contribute to improvements in the creation of music by its members. With main offices in England (London) and the United States (New York), it has branches in 32 countries throughout the world. Through its many activities which include the publication of "MIX MAG", the world's best-selling dance music trade magazine, DMC has sponsored the World DJ Championship for the last ten years with the support of Technics. At this venue which is held in London's Albert Hall or Wembley Stadium, the disc jockeys from 32 nations around the globe who have won top honors in the championships held in their respective countries put on their most impressive shows and compete to determine who will be crowned as world champion.

■ Connections

Rear panel connections

This model is connected with the other equipment using stereo connection cables (not included). Before proceeding with the connections, make absolutely sure that the power is turned off to the units concerned.

Connect the power cord after all the other connections have been completed.

Note [For (GU) area]

When using AC power cord, please use a power plug adaptor if the plug is not compatible with your household mains outlet.

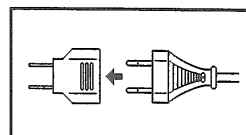

For your reference:

The grounding wire need not be connected if the turntable does not have a GND terminal.

Insertion of Connector

Even when the connector is perfectly inserted, depending on the type of inlet used, the front part of the connector may jut out as shown in the drawing. However there is no problem using the unit.

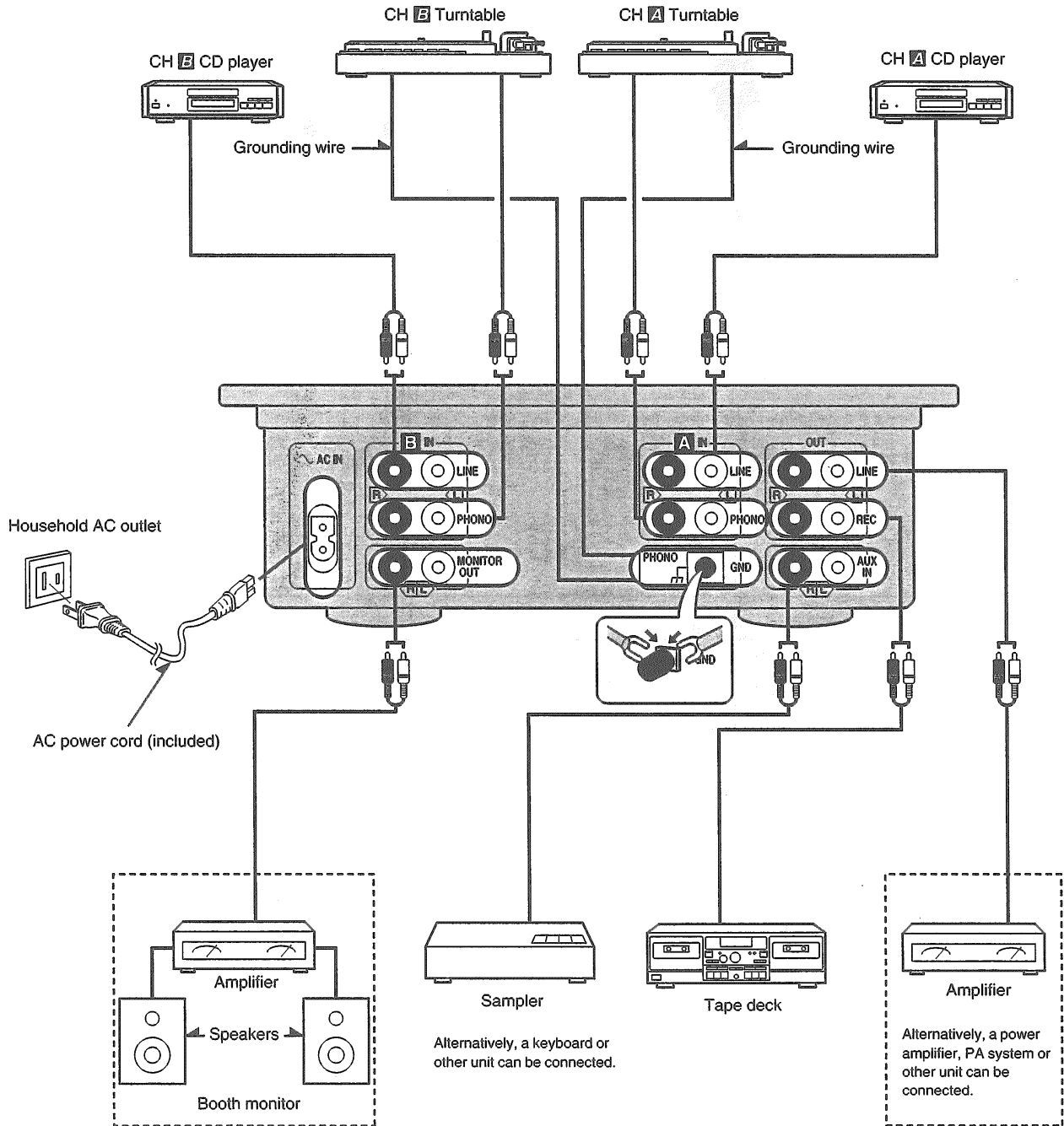
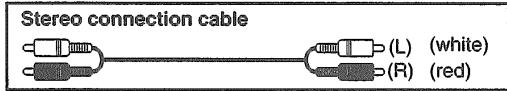
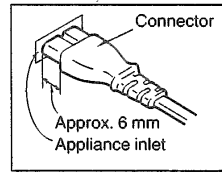

Front panel connections

To listen with the headphones:

- Before connecting the headphones, be absolutely sure to turn down the volume setting using the monitor volume level control, etc.
- Avoid listening for prolonged periods of time to prevent hearing damage.

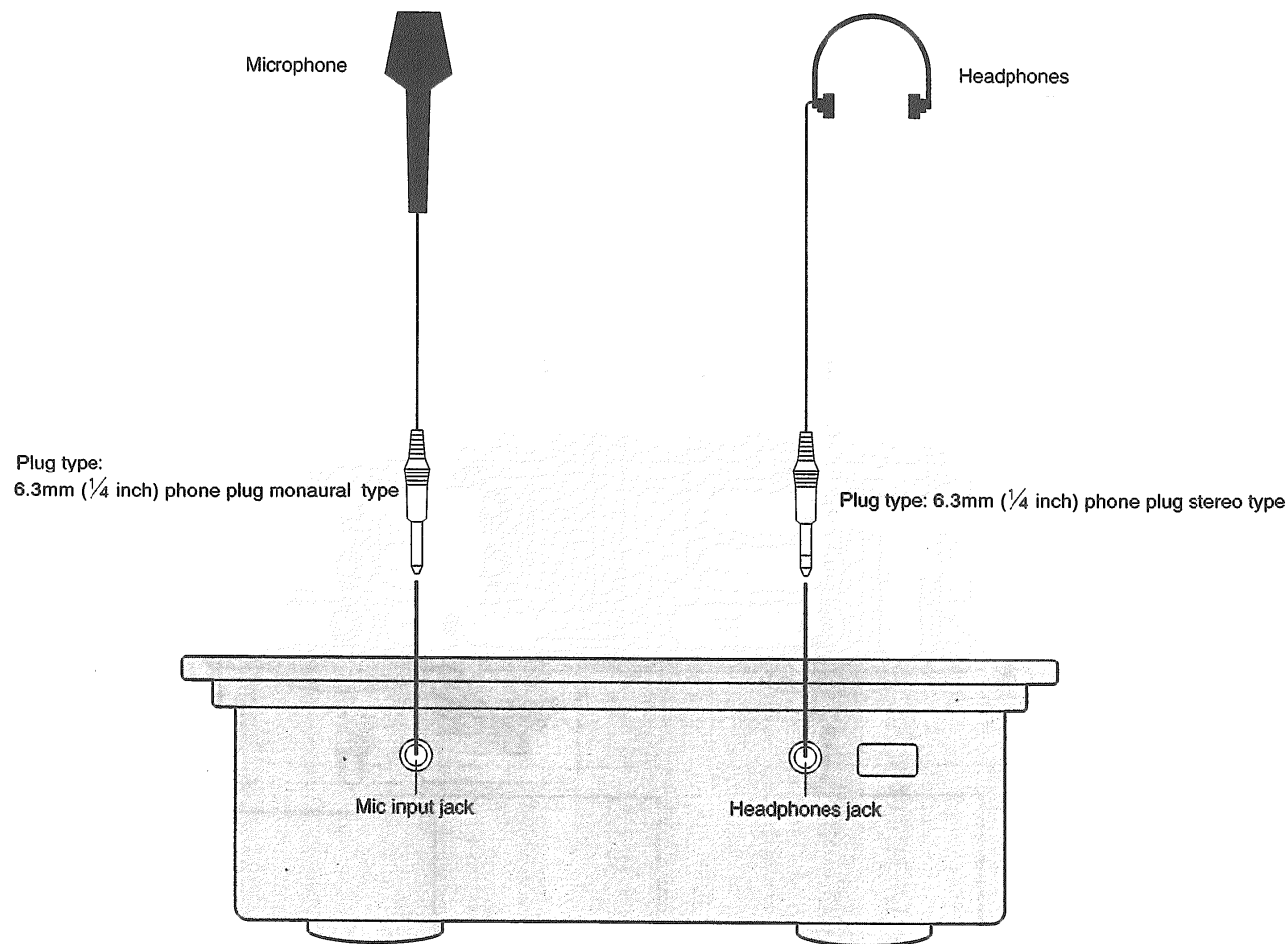

Connecting two audio mixers side by side

Connect the LINE OUT connector of the sub mixer to the AUX IN connector on the master mixer.

How to align the volume levels of the master and sub mixers:

Adjust the AUX/EFFECTOR volume level of the master mixer and master volume level of the sub mixer in such a way that the levels of the two models are identical.

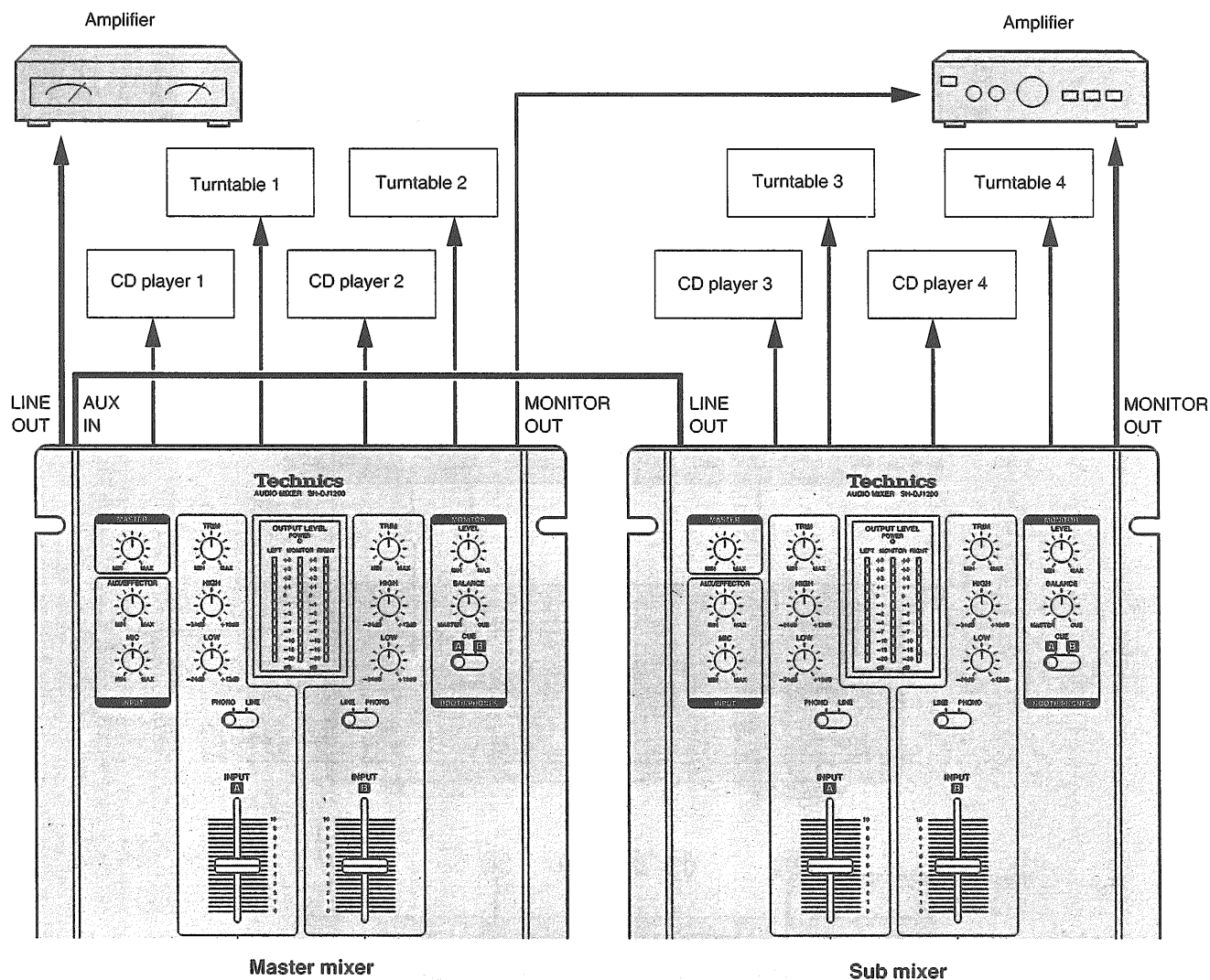

Names of the Parts

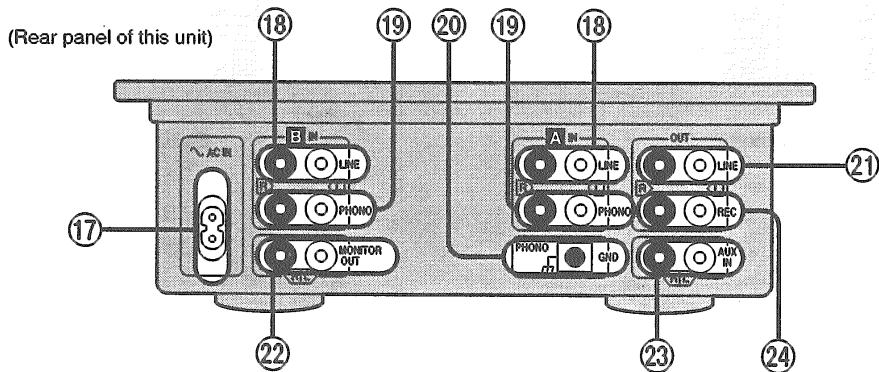
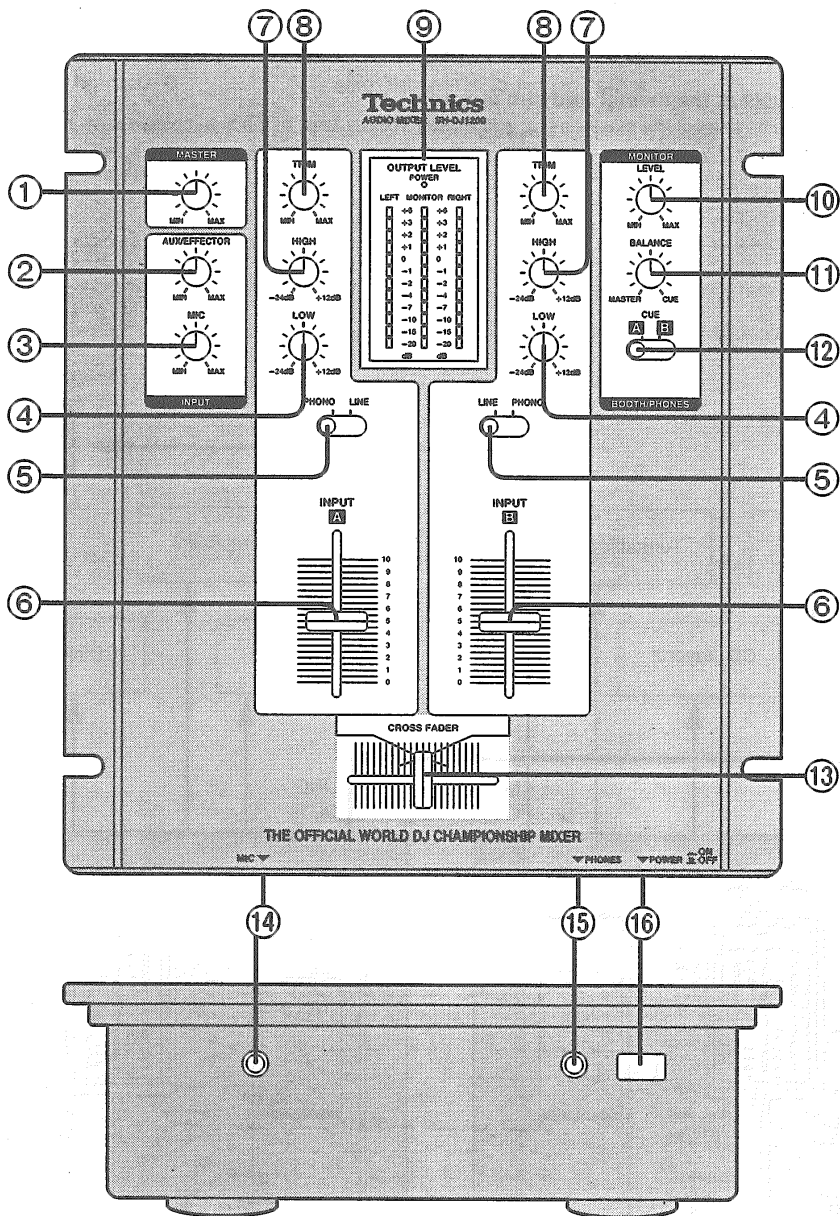

No.	Name	No.	Name
①	Master volume level control (MASTER)	⑬	CROSS FADER control This enables the balance between the CH A and CH B input levels to be adjusted.
②	AUX/EFFECTOR volume level control (AUX/EFFECTOR)	⑭	Mic input jack (MIC)
③	Mic volume level control (MIC)	⑮	Headphones jack (PHONES)
④	CH A (B) low-range level control (LOW)	⑯	Power button (POWER ON/OFF)
⑤	CH A (B) input selector (LINE, PHONO)	⑰	Power input socket (~AC IN)
⑥	INPUT A (B) control	⑱	CH A (B) LINE IN connector
⑦	CH A (B) high-range level control (HIGH)	⑲	CH A (B) PHONO IN connector
⑧	CH A (B) input sensitivity control (TRIM)	⑳	PHONO GND terminal The grounding wire of the turntable must be secured to the ground terminal in order to prevent hum and noise.
⑨	OUTPUT LEVEL meter This indicates the LINE OUT (L and R channels) and MONITOR OUT output levels.	㉑	LINE OUT connector
⑩	Monitor volume level control (MONITOR LEVEL)	㉒	MONITOR OUT connector
⑪	Monitor balance control (MONITOR BALANCE) This adjusts the balance between the LINE OUT source and source selected by the CUE switch.	㉓	AUX IN connector
⑫	Headphones monitor selector (CUE) This selects the source to be monitored regardless of the positions of the faders.	㉔	REC OUT connector

■ Proper Use of the SH-DJ1200

New functions not available on past DJ mixers, the MONITOR BALANCE control ⑪ and the MONITOR OUT connector ㉒, have been added to this unit. Read the following explanations carefully before operating the SH-DJ1200.

■ MONITOR BALANCE control ⑪

Select CUE (completely to the right)

- Works as past general DJ mixer monitors.
- Allows the CH (A/B) input selected with the CUE control ⑫ to be monitored regardless of the position of the input and cross faders.

Select MASTER (completely to the left)

- Disregards the source selected with the CUE control.
- Allows monitoring of the output from the LINE OUT connector ㉑.

Select the center

- Allows the CH (A/B) input selected with the CUE control ⑫ and the output from the LINE OUT connector ㉑ to be mixed and monitored.

■ MONITOR OUT connector ㉒

Outputs the same signal as the headphones. Connect the monitor amplifier when monitoring from the speakers without headphones as in independent DJ booths.
Connect the general output amplifier to the LINE OUT connector ㉑.

■ Audio Mixer Slide Volume Control Replacement Instructions

※●CROSS FADER KIT (RFKVHDJ1200A)

●CROSS FADER VR	(1)
●P.C.B.	(1)
●CONNECTOR	(1)
●BRACKET	(1)
●HIMELON	(2)
●SCREW	(2)
●KNOB	(1)

●CHANNEL FADER KIT (RFKVHDJ1200B)

●CHANNEL FADER VR	(1)
●P.C.B.	(1)
●CONNECTOR	(1)
●BRACKET	(1)
●HIMELON	(2)
●SCREW	(2)
●KNOB	(1)

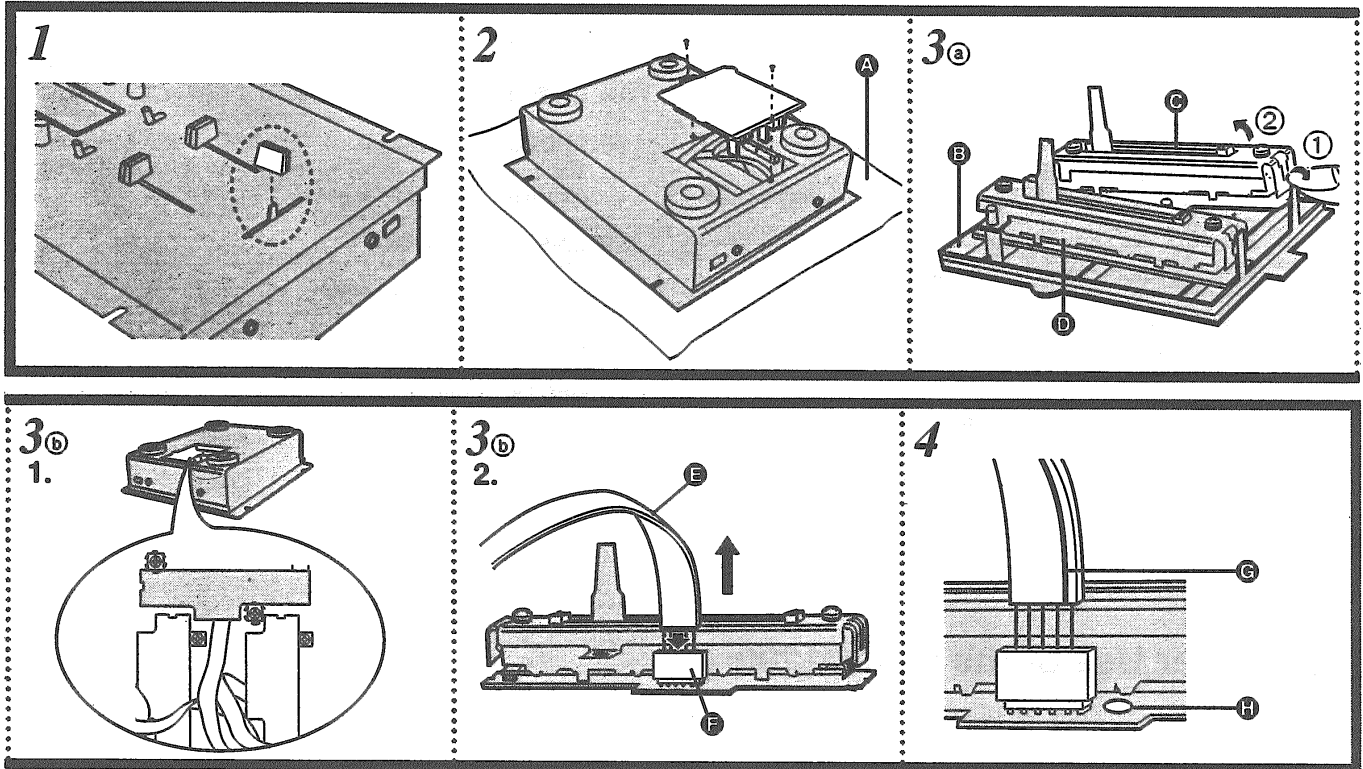

This unit comes with two spare slide volume controls (one for the cross fader and one for the channel fader) mounted on its bottom panel. If the movement of one of the faders should become impaired, follow the steps outlined below to replace the fader. These steps describe the replacement of the cross fader as an example of the procedure to be followed which is the same for replacing the channel fader.

1 Remove the knob of the slide volume control to be replaced.

2 Turn the bottom panel so that it is facing up and remove the bottom cover.

(Remove the two screws.)

Ⓐ Soft cloth, etc.

3 Remove the slide volume control to be replaced.

Ⓐ How to remove the new slide volume control on bottom panel

Ⓑ Bottom cover

Ⓒ For cross fader

Ⓓ For channel fader

Ⓑ How to remove the old slide volume control

1. Remove the two screws and remove the slide volume control.

2. Disconnect the cable leading from the slide volume control to be replaced by pressing down on the head section of the connector.

Ⓔ Cable

Ⓕ Connector

4 Install the new slide volume control.

(Align the line on the cable with the "1" marking below the connector and use the screws for mounting.)

Ⓖ Line

Ⓖ "1" marking

5 Attach the bottom cover.

6 Attach the knob to the control.

■ Troubleshooting Guide

Before requesting service for this unit, check the chart below for a possible cause of the problem you are experiencing. Some simple checks or a minor adjustment on your part may eliminate the problem and restore proper operation. If you are in doubt about some of the check points, or if the remedies indicated in the chart do not solve the problem, refer to the directory of Authorized Service Centers (enclosed with this unit) to locate a convenient service center, or consult your dealer for instructions.

Symptom	Checkpoint	Remedial action
No power.	Has the power plug been disconnected?	Connect the power plug securely.
No sound even when power is supplied.	Has the input selector control been set to another source?	Check the source and set the control to the proper position.
	Have any of the units been wrongly connected?	Connect the units properly.
	Is the master level control or another volume level control at the MIN position?	Adjust the volume level controls correctly.
Left and right sound is reversed.	Have any of the units been connected with the left and right channels reversed?	Connect the channels correctly.
Low hum or buzz is heard during play.	Is there a fluorescent light or other electrical appliance or its power cord near any of the connecting cords?	Place the fluorescent light, other appliances or their power cords as far away from the audio mixer as possible.
	Has the turntable's grounding wire been disconnected?	Connect the grounding wire securely.
Fader (slide volume control) fails to move smoothly.	Is one of the faders worn?	Replace with a new fader. (Refer to the Slide Volume Replacement Instructions provided separately.)

Operation Checks and Main Component Replacement Procedures

NOTE

1. This section describes procedures for checking the operation of the major printed circuit boards and replacing the main components.
2. For reassembly after operation checks or replacement, reverse the respective procedures. Special reassembly procedures are described only when required.
3. Illustrated screws are equivalent to actual size.
4. [] indicates parts No.

Checking for the P.C.B. (Output P.C.B. / Input A P.C.B. / Input B P.C.B. / Tone control A P.C.B. / Tone control B P.C.B. / Monitor P.C.B.)

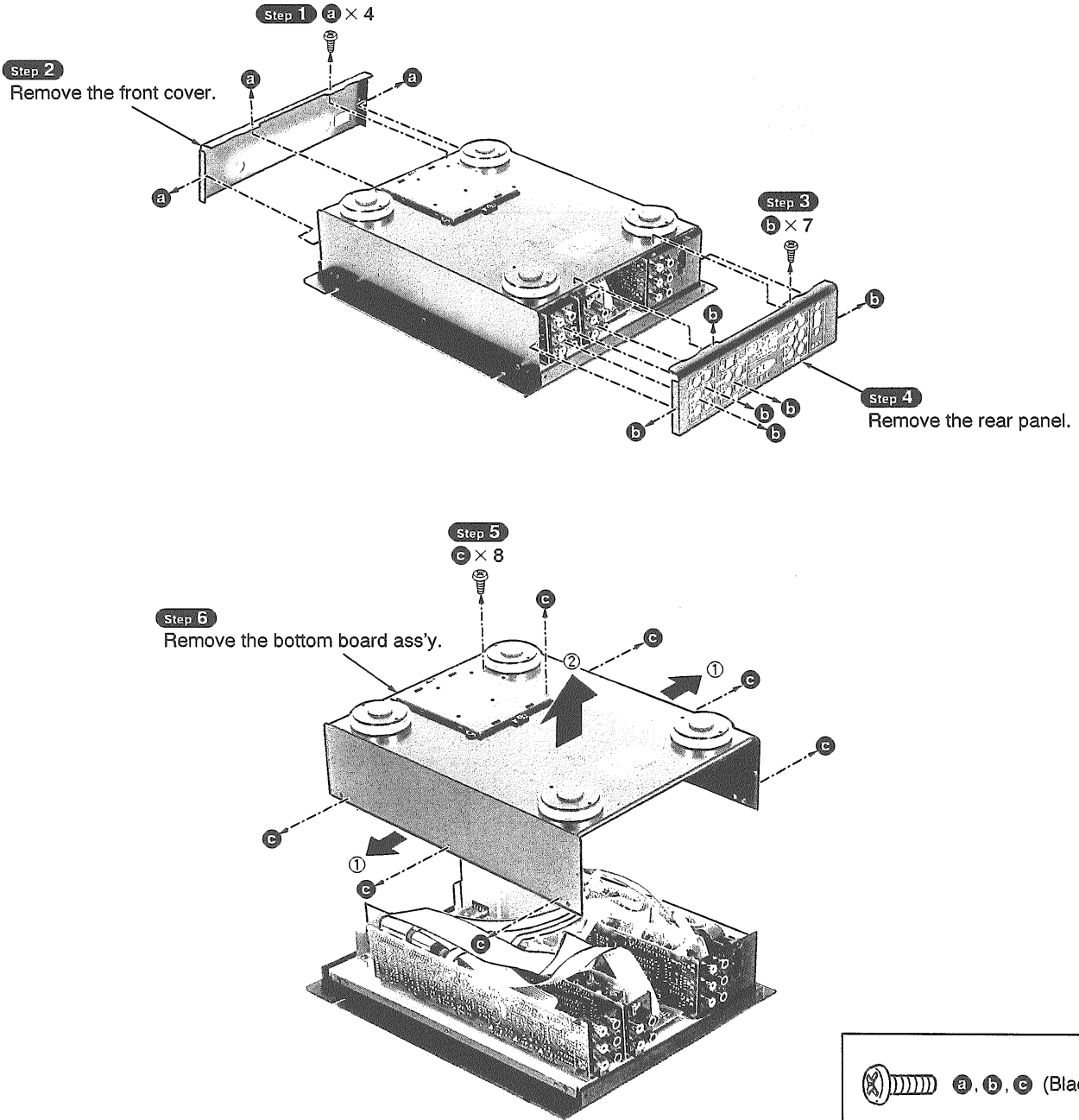

• Check the P.C.B. as shown below.

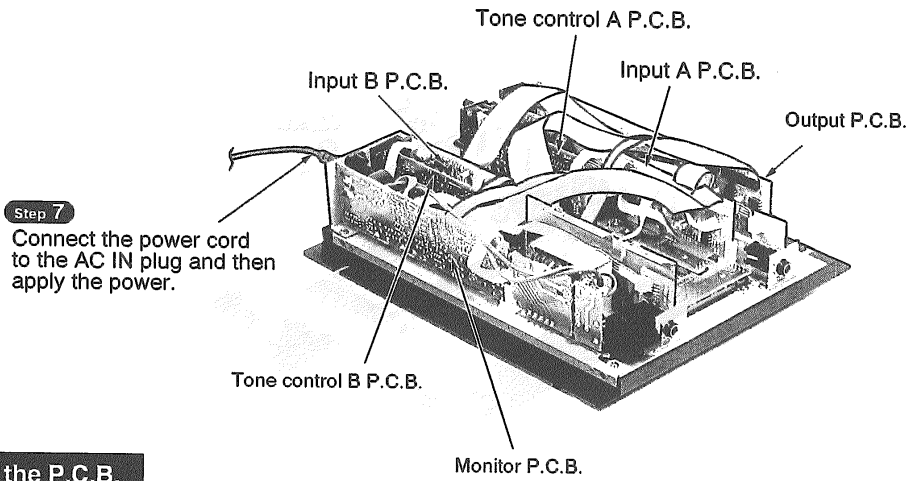

Step 7
Connect the power cord to the AC IN plug and then apply the power.

Removal for the P.C.B.

• Follow the item **Step 1** ~ **Step 6** in checking procedures on page.

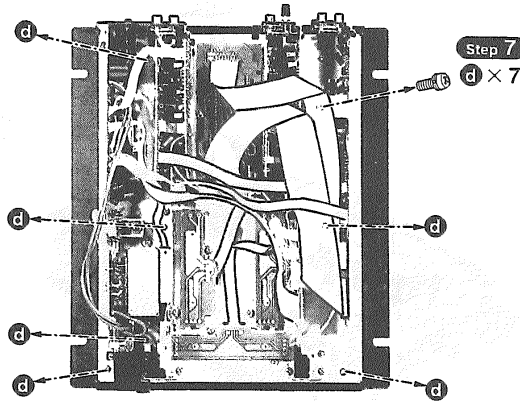

↓ (Upset the unit)

Step 8
Pull out the master knobs (5 pcs.), trim knobs (6 pcs.) and fader knobs (3 pcs.).

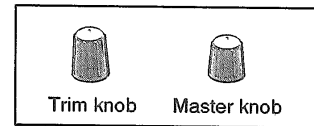
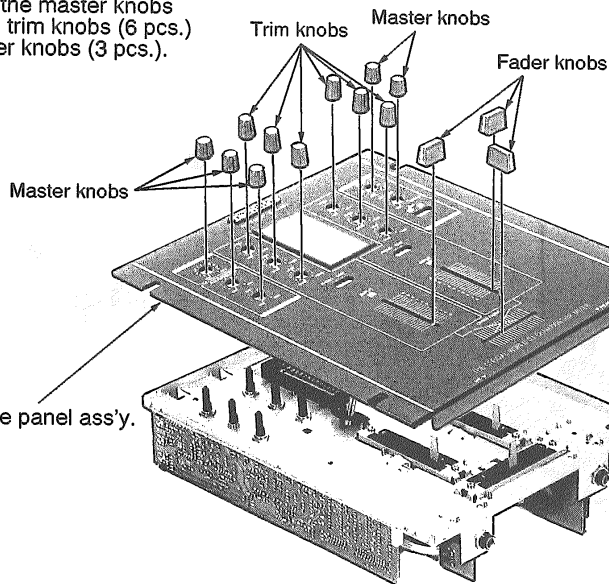

Step 9
Remove the panel ass'y.

NOTE

Handle with care the knobs because the trim knobs and master knobs are different size.

Step 10
Remove the 11 nuts.

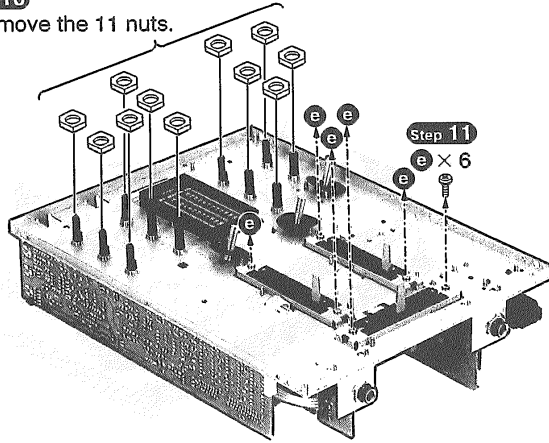

Step 11
e × 6



[XYN3+C5S]

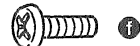

[XTB3+8J]

↓ (Upset the unit)

Step 12
Remove the 3 connectors (CN102,103,104), and then remove channel fader A, channel fader B and cross fader P.C.B's.

Step 13
f × 2

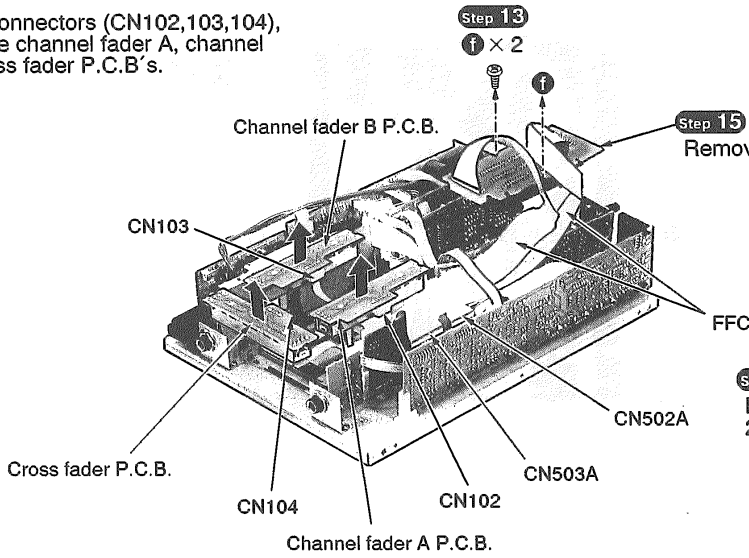

Step 15
Remove the LED P.C.B..

Step 14
Remove the FFC from the 2 connectors (CN502A,503A).

Step 16
Remove the 9 connectors as shown below.

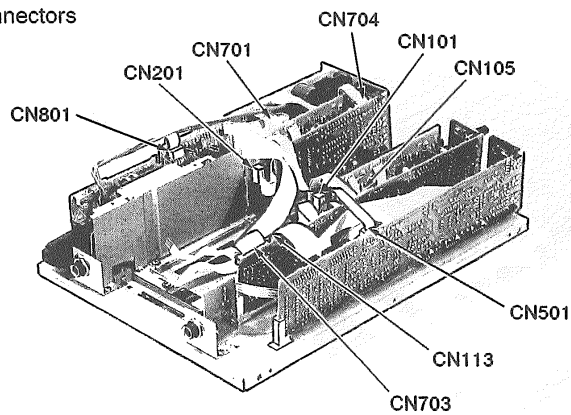

Removal for the connector.

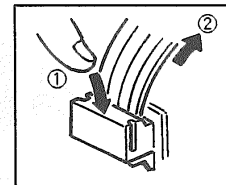

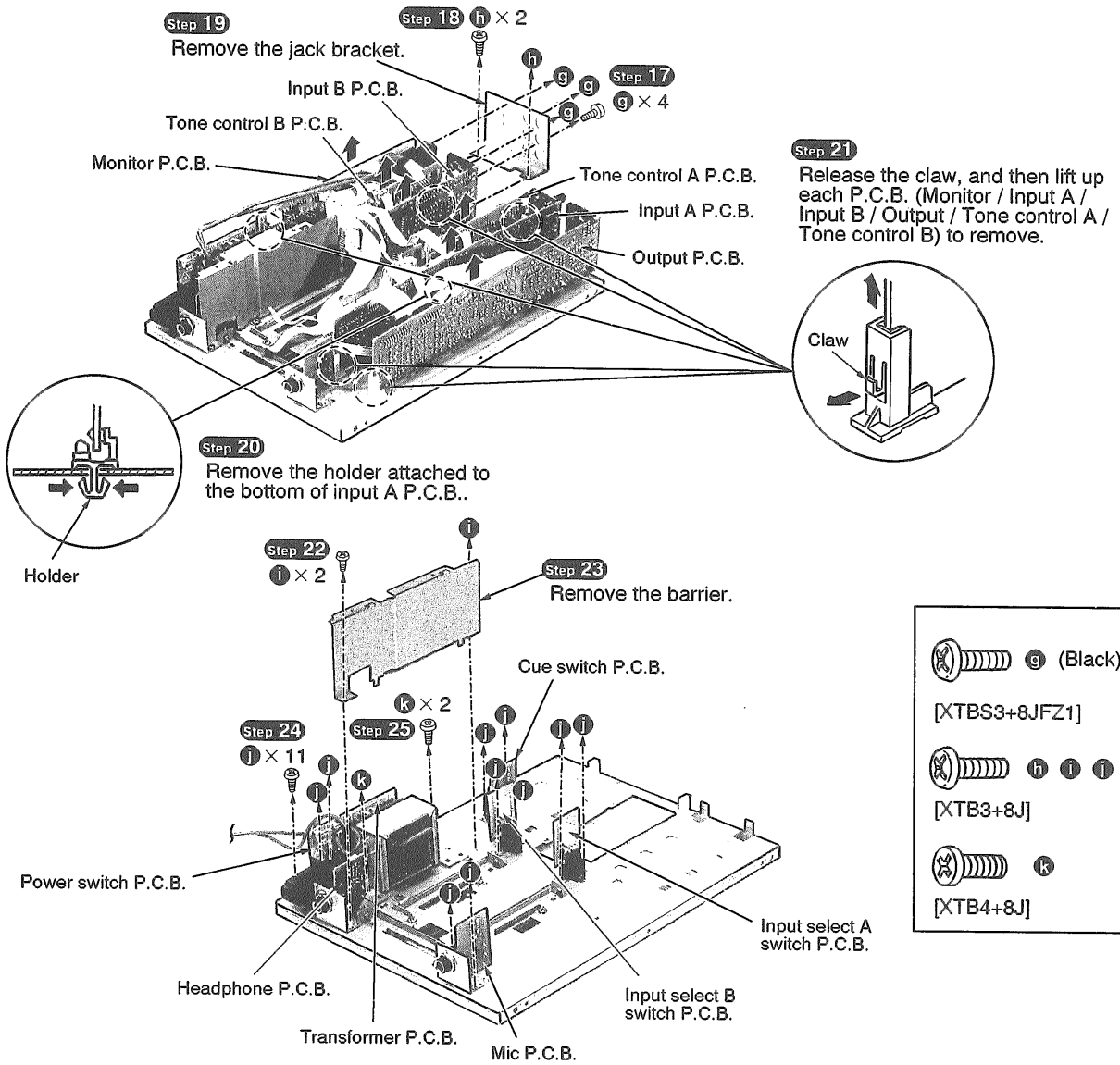

Lead wire arrangement

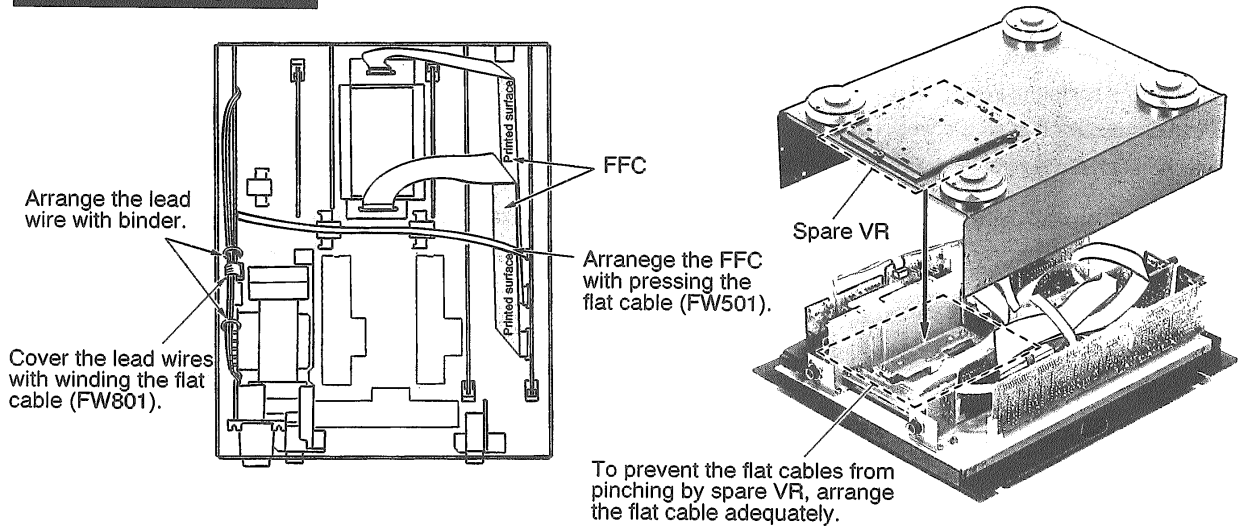

■ Schematic Diagram

Notes:



- S101 : CH. [A] input selector switch in "PHONO" position.
- S201 : CH. [B] input selector switch in "PHONO" position.
- S701 : Headphones monitor selector switch in "[A]" position.
- S801 : Power ON/OFF switch in "ON" position.
- VR101-1, 101-2 : CH. [A] input sensitivity control.
- VR102-1, 102-2 : CHANNEL FADER control (INPUT [A]).
- VR103-1, 103-2 : CHANNEL FADER control (INPUT [B]).
- VR104-1, 104-2 : CROSS FADER control.
- VR201-1, 201-2 : CH. [B] input sensitivity control.
- VR301-1, 301-2 : CH. [A] high-range level control.
- VR302-1, 302-2 : CH. [A] low-range level control.
- VR401-1, 401-2 : CH. [B] high-range level control.
- VR402-1, 402-2 : CH. [B] low-range level control.
- VR501-1, 501-2 : Master volume level control.
- VR601 : Mic volume level control.
- VR602-1, 602-2 : AUX/EFFECTOR volume level control.
- VR701-1, 701-2 : Monitor balance control.
- VR702-1, 702-2 : Monitor volume level control.
- VR102S-1, 102S-2 : CHANNEL FADER control (spare).
- VR104S-1, 104S-2 : CROSS FADER control (spare).

● The voltage value and waveforms are the reference voltage of this unit measured by DC electronic voltmeter (high-impedance) and oscilloscope on the basis of chassis.

Accordingly, there may arise some error in voltage values and waveforms depending upon the internal impedance of the tester or the measuring unit.

● Important safety notice:

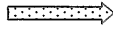
Components identified by Δ mark have special characteristics important for safety. When replacing any of these components, use only manufacturer's specified parts.

-  : +B Line
-  : PHONO ([A], Lch) Signal Line
-  : -B Line
-  : MIC Signal Line

- This schematic diagram may be modified at any time with the development of new technology.

● Caution!

IC and LSI are sensitive to static electricity.

Secondary trouble can be prevented by taking care during repair.

Cover the parts boxes made of plastics with aluminum foil.

Ground the soldering iron.

Put a conductive mat on the work table.

Do not touch the legs of IC or LSI with the fingers directly.

【For U.S.A. model only】

CAUTION : FOR CONTINUED PROTECTION AGAINST FIRE HAZARD, REPLACE ONLY WITH SAME TYPE F1 315mA 125V FUSE.



RISK OF FIRE-REPLACE FUSE AS MARKED.

【For CANADA model only】

FUSE CAUTION

 These symbols located near the fuse indicates that the fuse used is a fast operating type. For continued protection against fire hazard, replace with the same type fuse. For fuse rating, refer to the marking adjacent to the symbol.

 Ce symbole indique que le fusible utilisé est à rapide. Pour une protection permanente, n' utiliser que des fusibles de même type. Ce dernier est indiqué là où le présent symbole est apposé.

A INPUT A CIRCUIT (P.C. Board: on page 24)

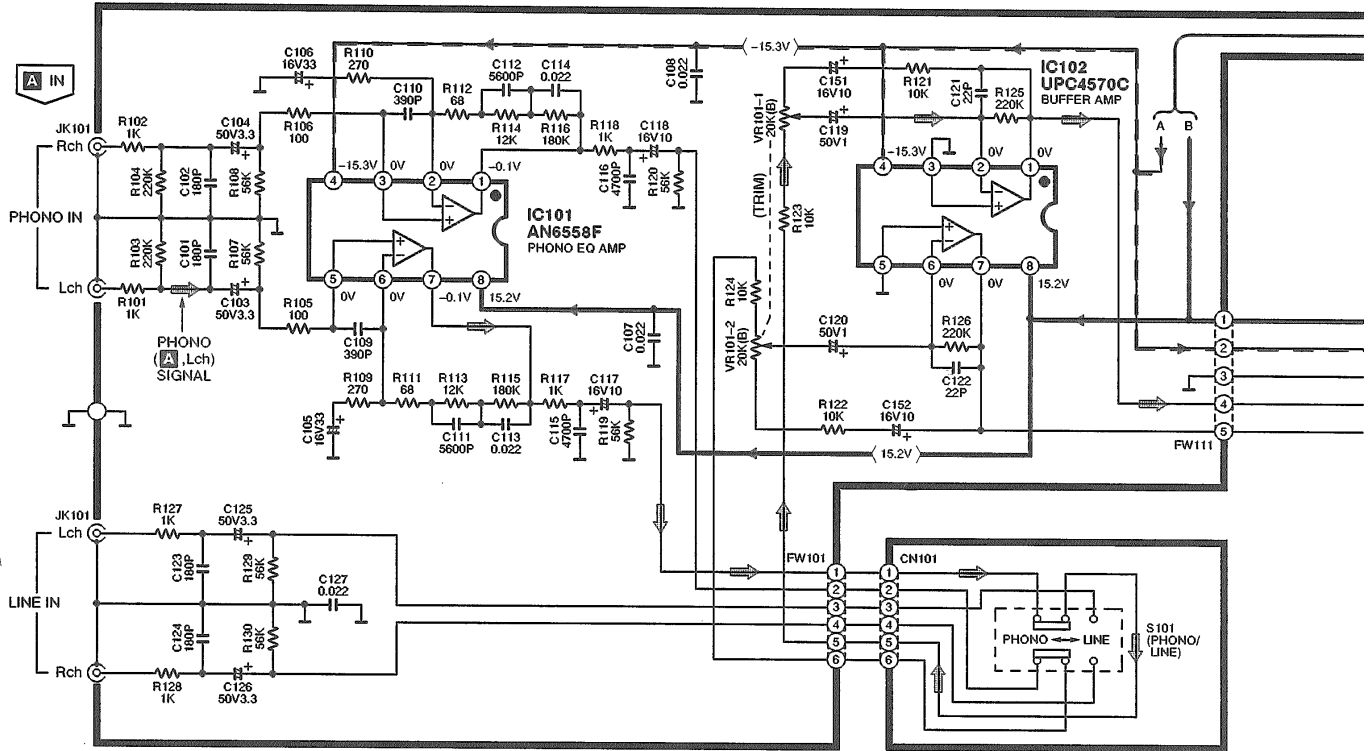

C INPUT SELECT A SWITCH CIRCUIT
(P.C. Board: on page 23)

B INPUT B CIRCUIT (P.C. Board: on page 23)

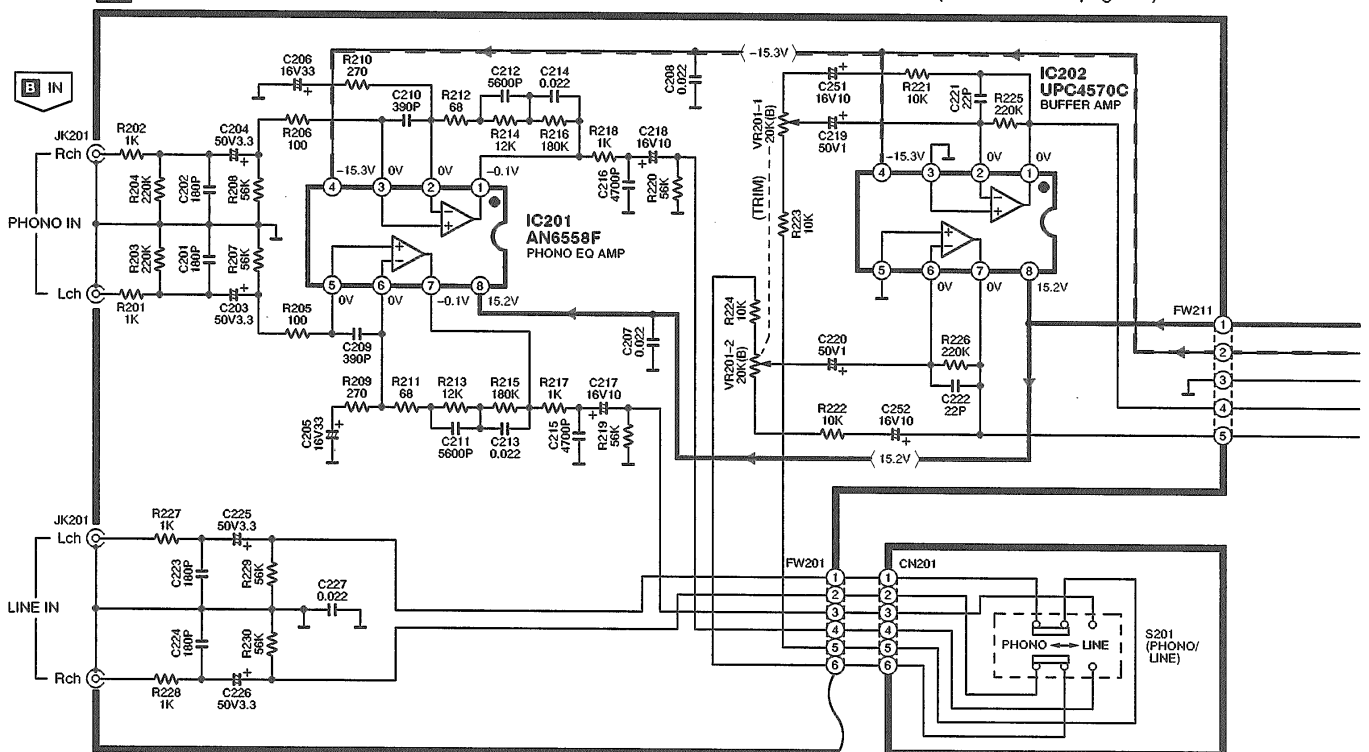

D INPUT SELECT B SWITCH CIRCUIT
(P.C. Board: on page 23)

R CHANNEL FADER A (SPARE) CIRCUIT
(P.C. Board: on page 26)

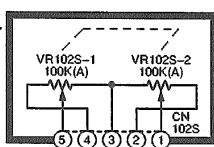

S CROSS FADER (SPARE) CIRCUIT
(P.C. Board: on page 26)

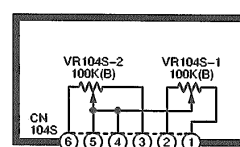

E TONE CONTROL A CIRCUIT (P.C. Board: on page 25)

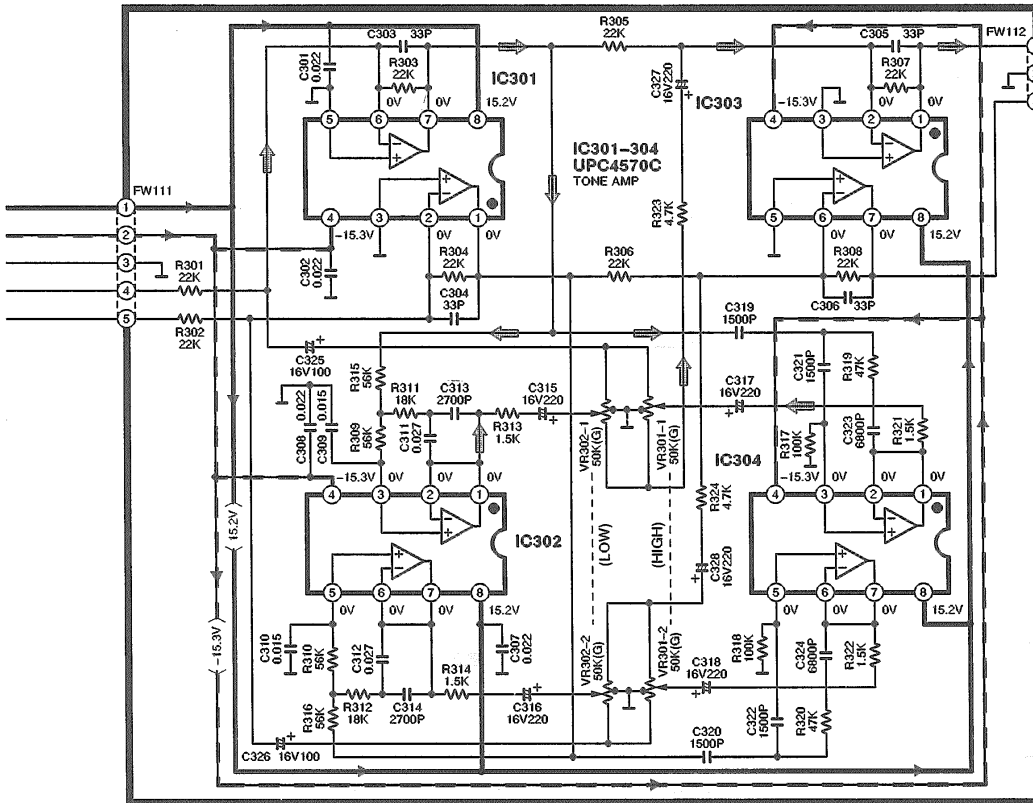

F TONE CONTROL B CIRCUIT (P.C. Board: on page 25)

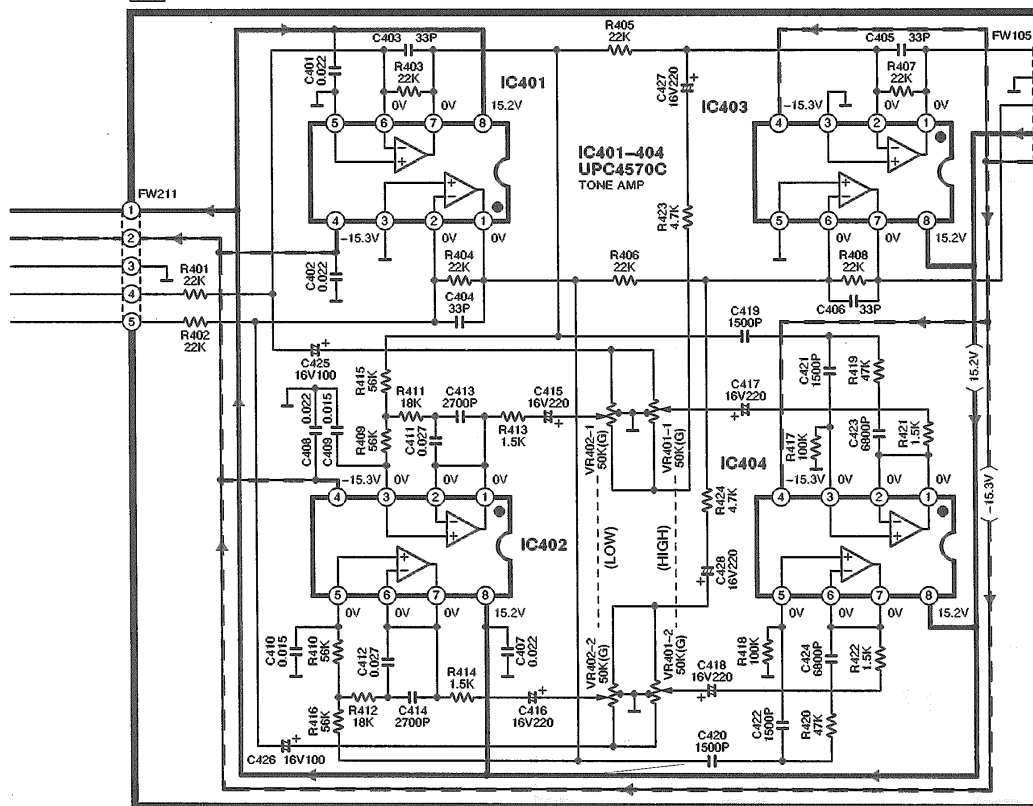

G CHANNEL FADER A CIRCUIT (P.C. Board: on page 27)

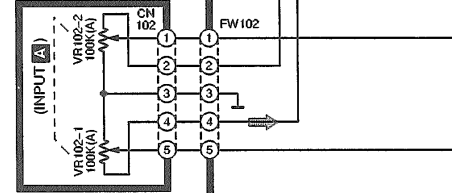

H CROSS FADER CIRCUIT (P.C. Board: on page 27)

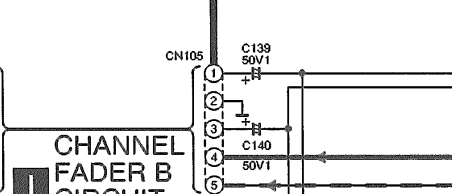

I CHANNEL FADER B CIRCUIT (P.C. Board: on page 27)

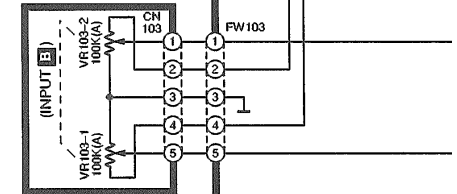

J MIC CIRCUIT (P.C. Board: on page 26)

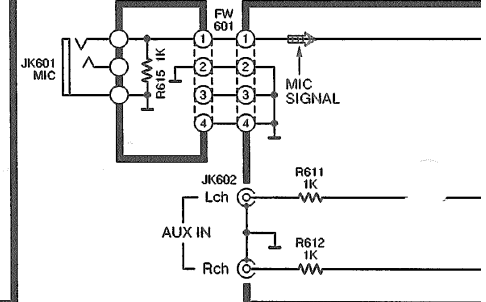

A INPUT A CIRCUIT (P.C. Board: on page 24)

L CUE SWITCH CIRCUIT
(P.C. Board: on page 23)

K OUTPUT CIRCUIT (P.C. Board: on page 24)

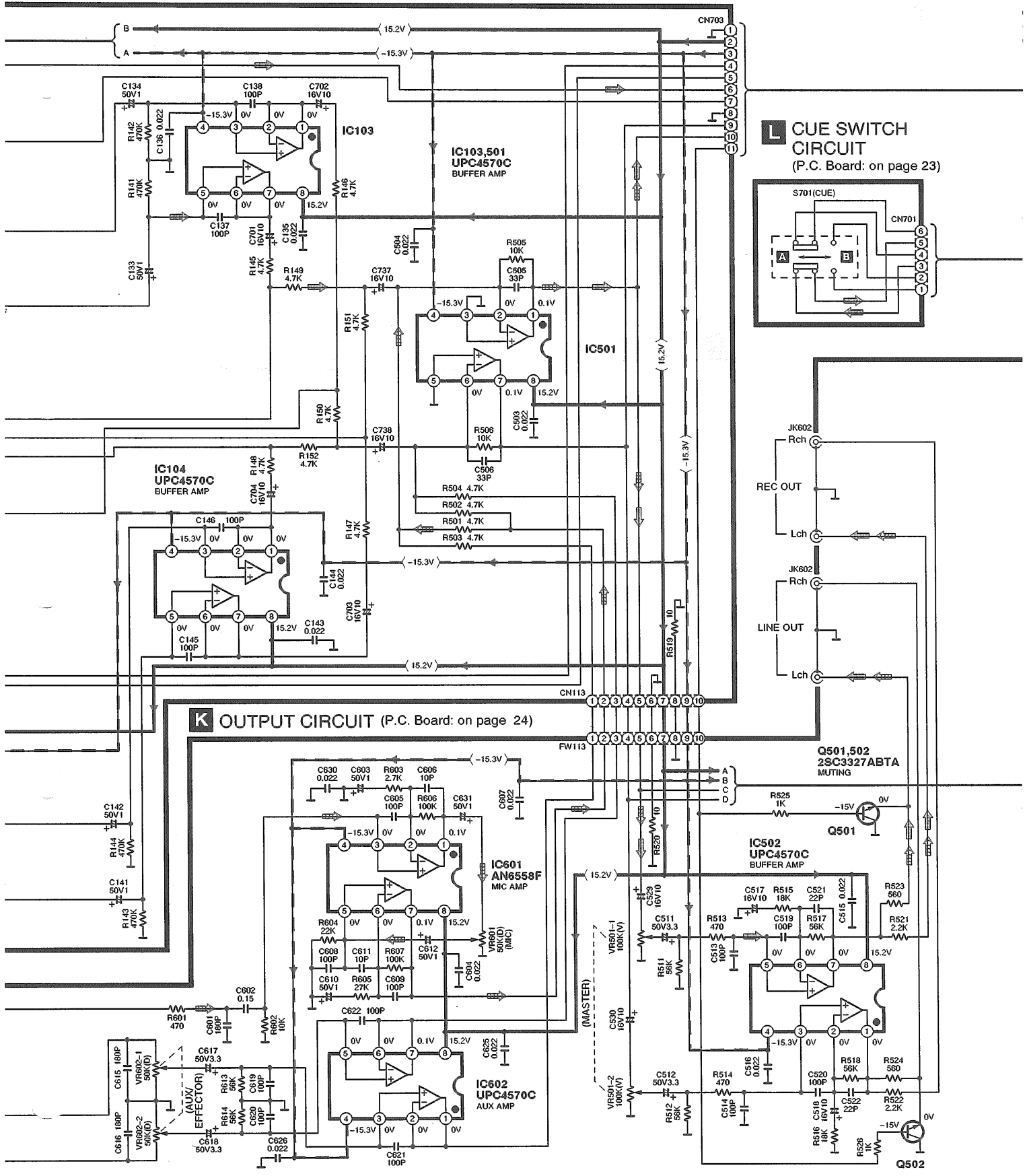

M MONITOR CIRCUIT (P.C. Board: on page 23)

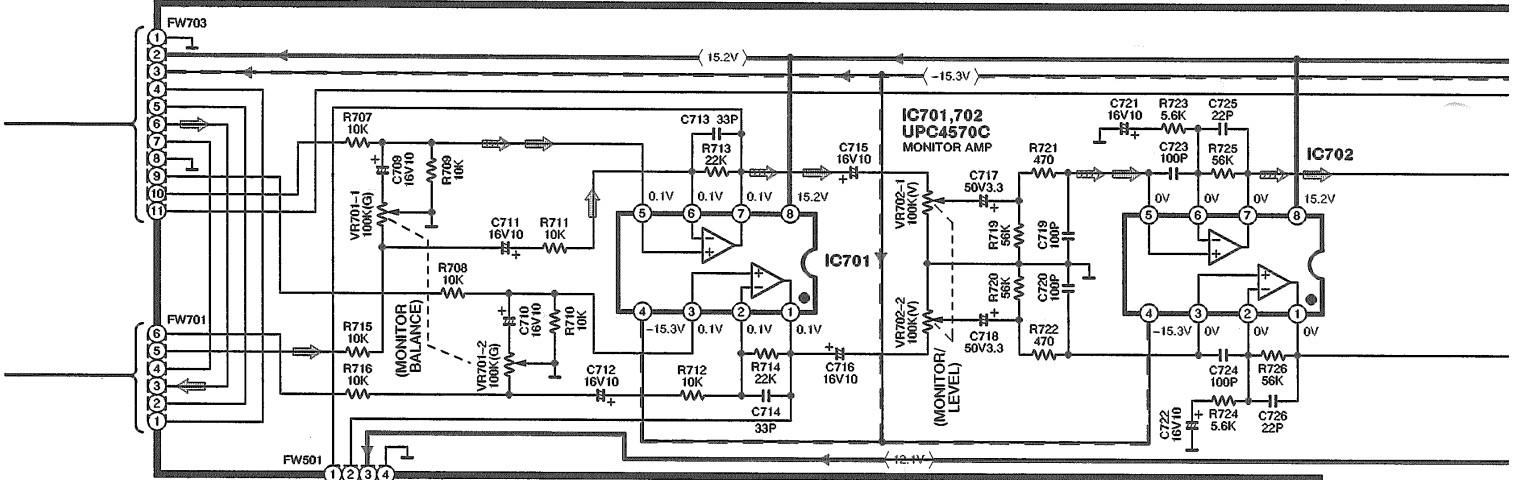

K OUTPUT CIRCUIT (P.C. Board: on page 24)

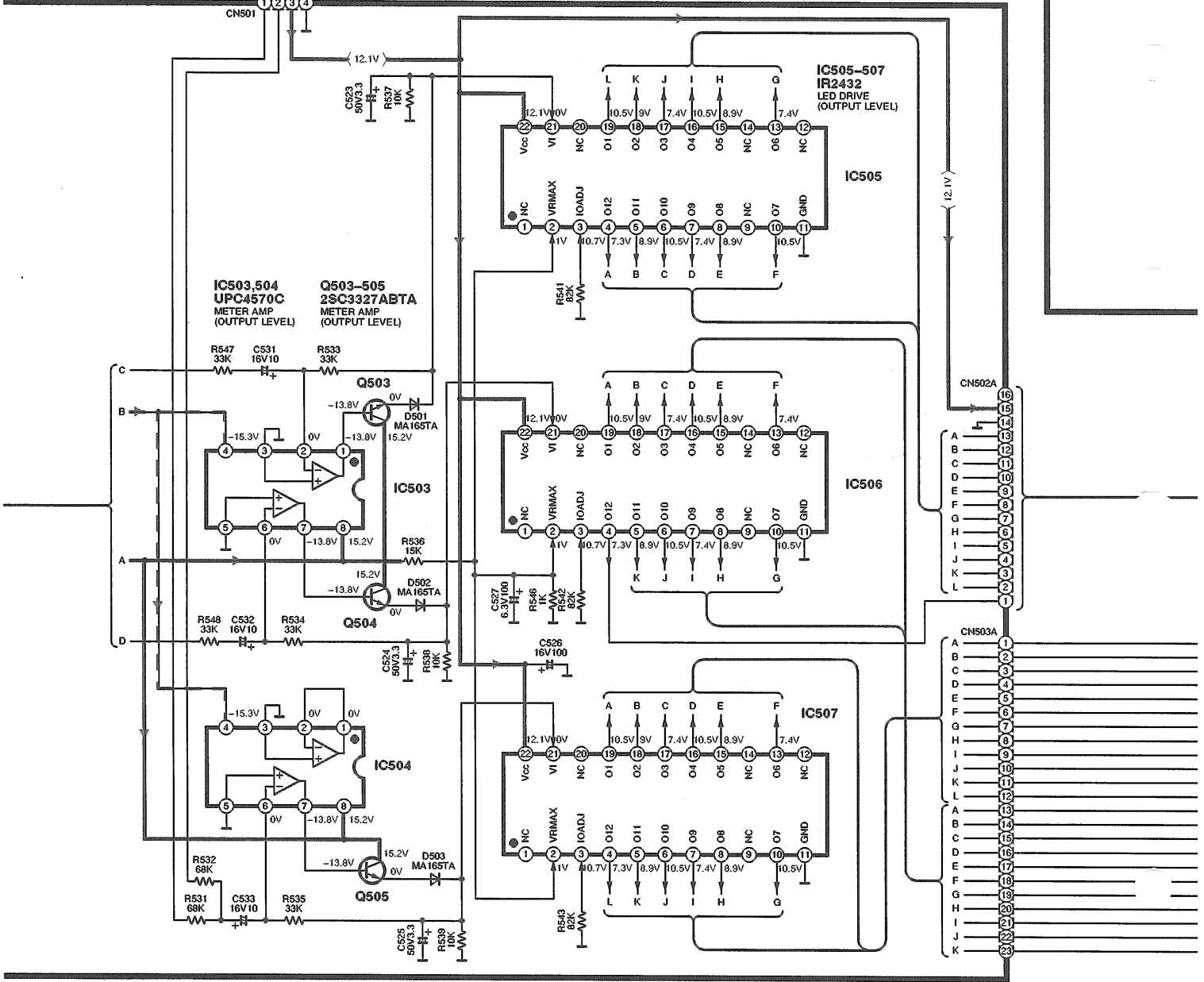

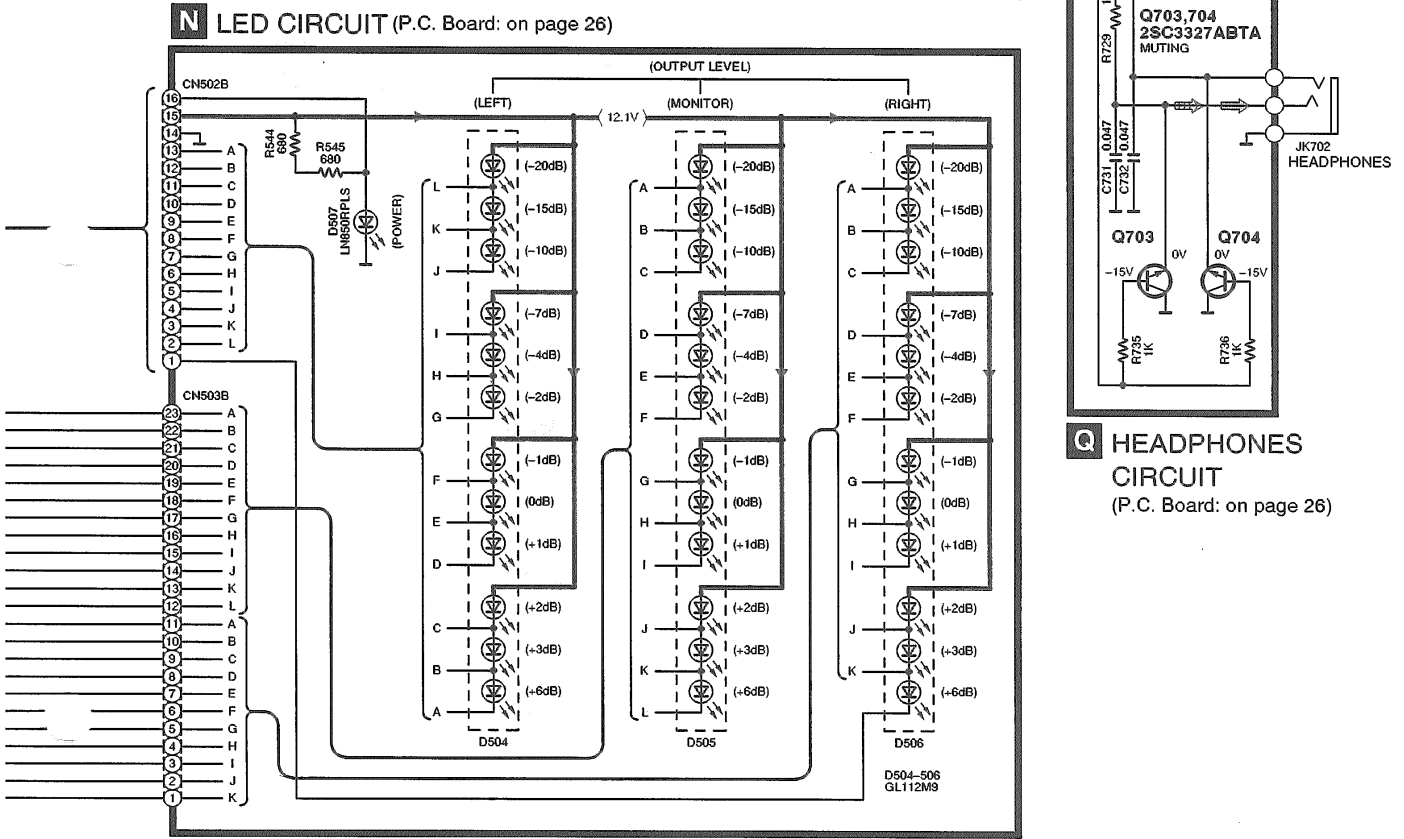
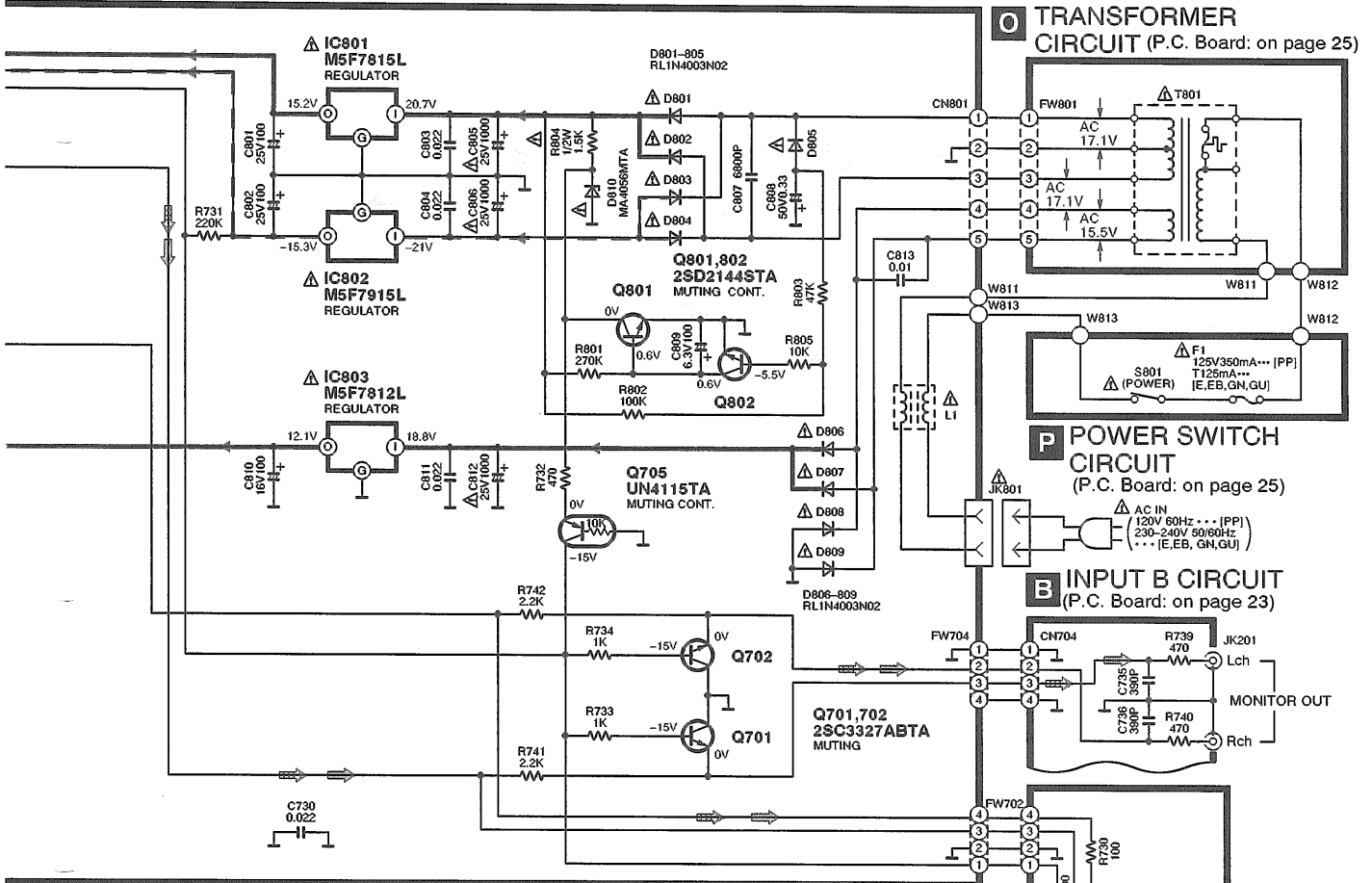

Block Diagram

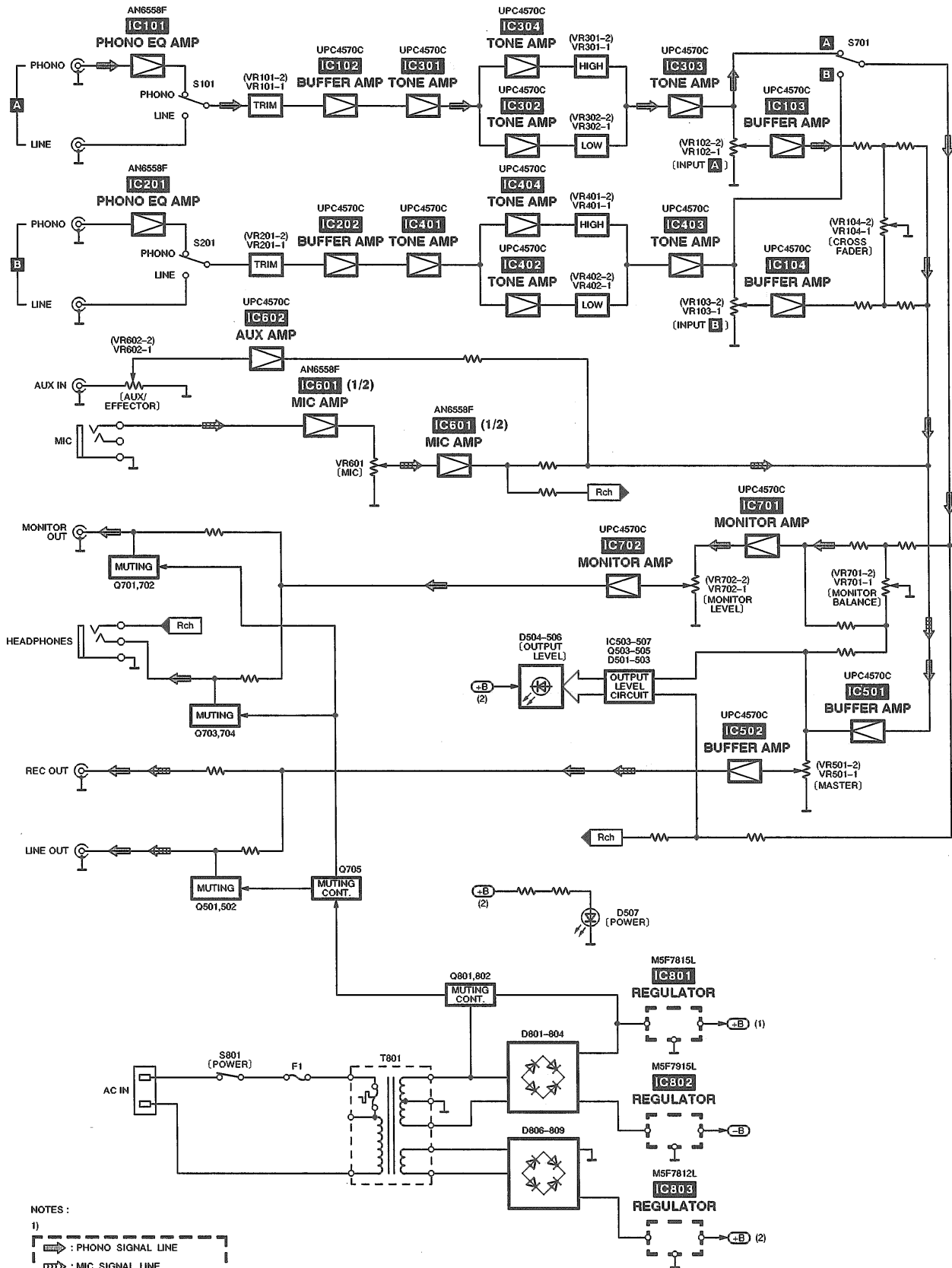

NOTES :
 1) : PHONO SIGNAL LINE
 : MIC SIGNAL LINE
 2) () INDICATES OF RIGHT CHANNEL

Printed Circuit Boards

(This circuit board diagram may be modified at any time) with the development of new technology.

B INPUT B P.C.B.

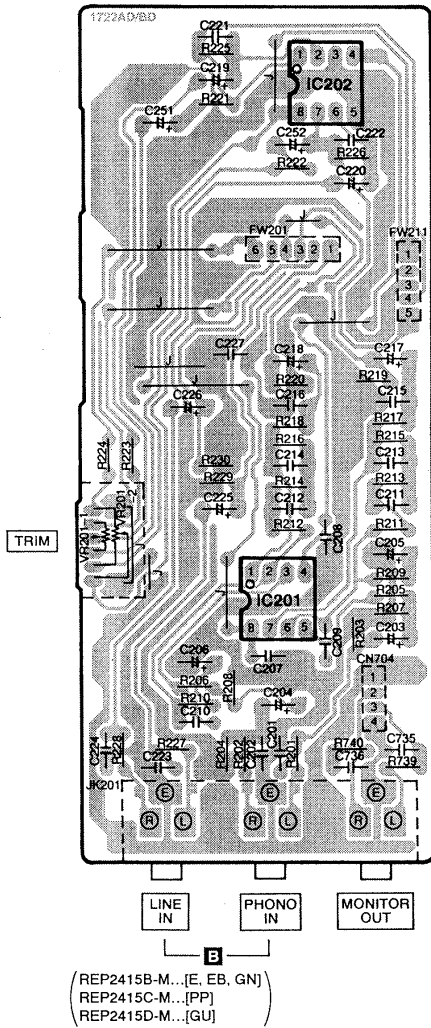

C INPUT SELECT A SWITCH P.C.B.

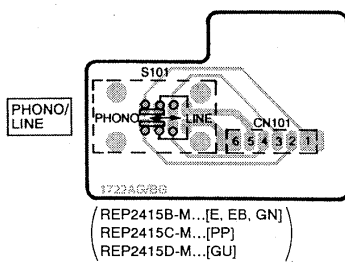

D INPUT SELECT B SWITCH P.C.B.

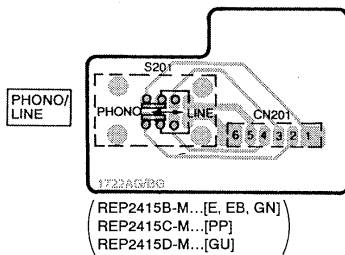

M MONITOR P.C.B.

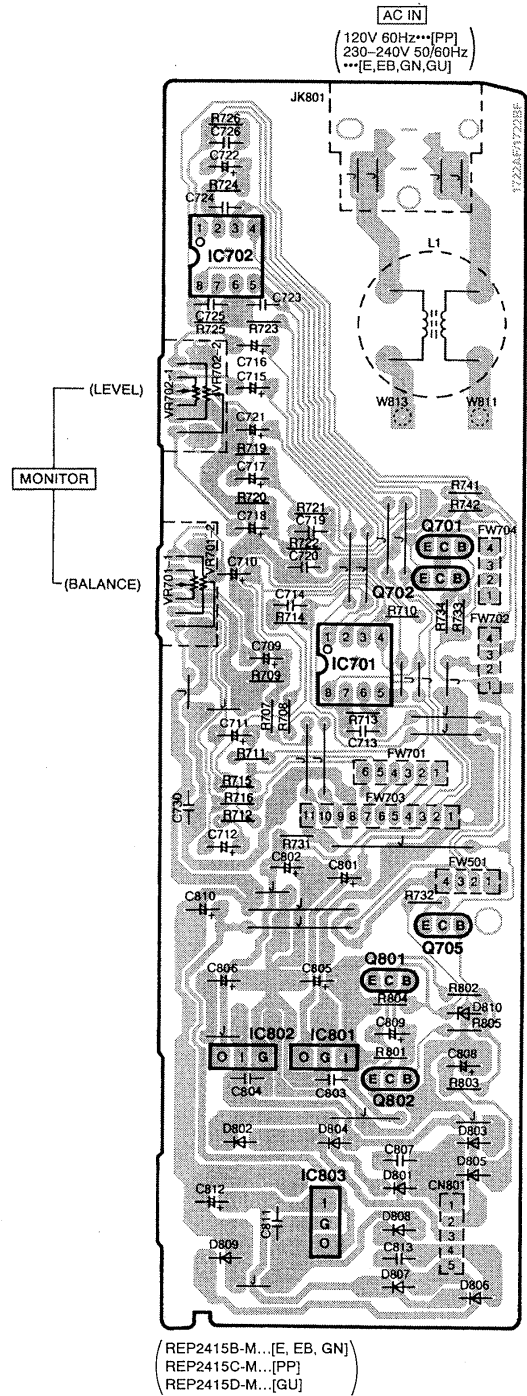

L CUE SWITCH P.C.B.

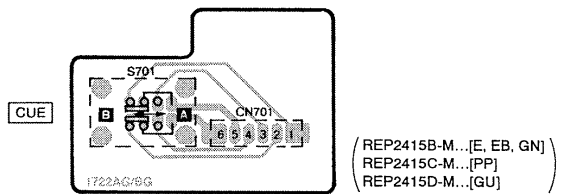

A INPUT P.C.B.

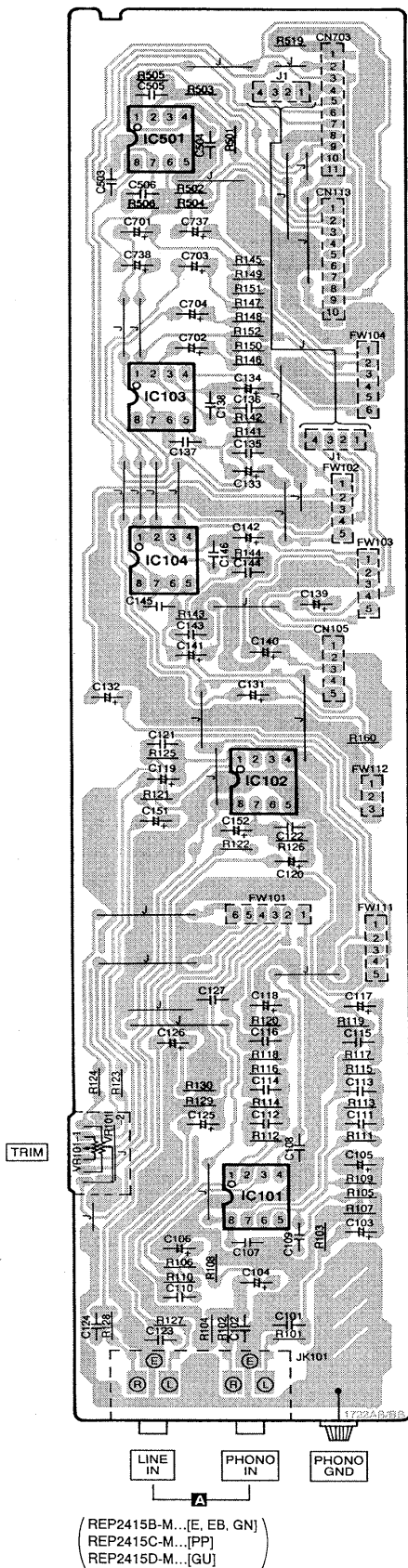

K OUTPUT P.C.B.

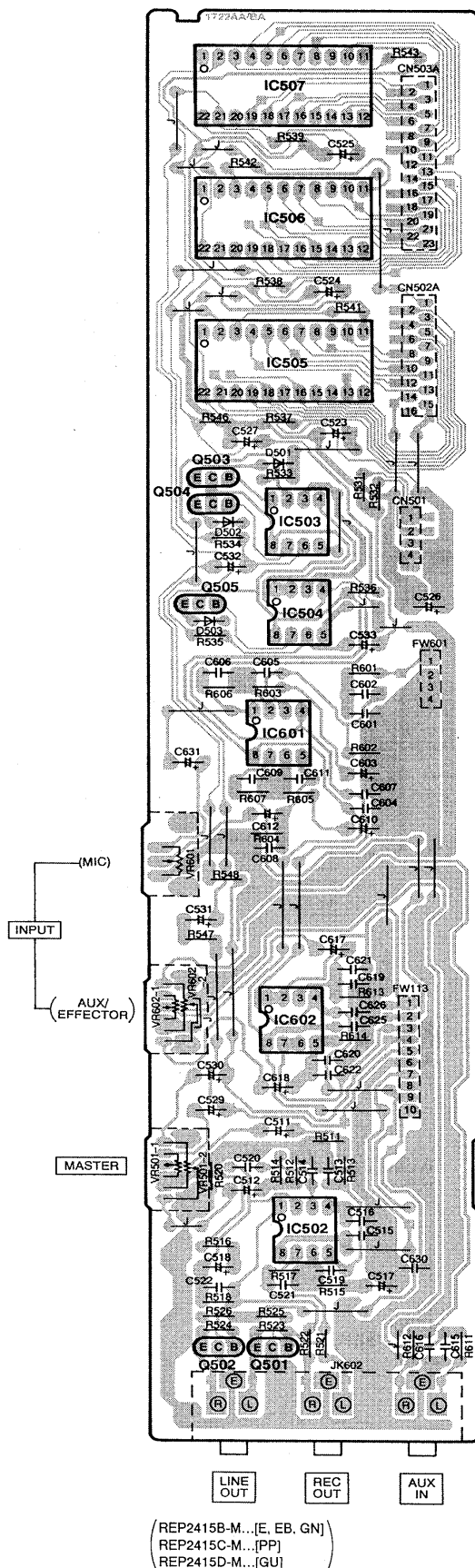

E TONE CONTROL A P.C.B.

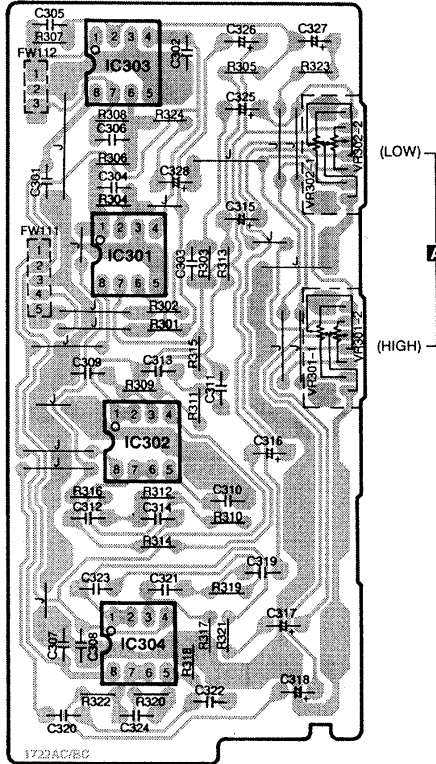

(REP2415B-M...[E, EB, GN]
 REP2415C-M...[PP]
 REP2415D-M...[GU])

F TONE CONTROL B P.C.B.

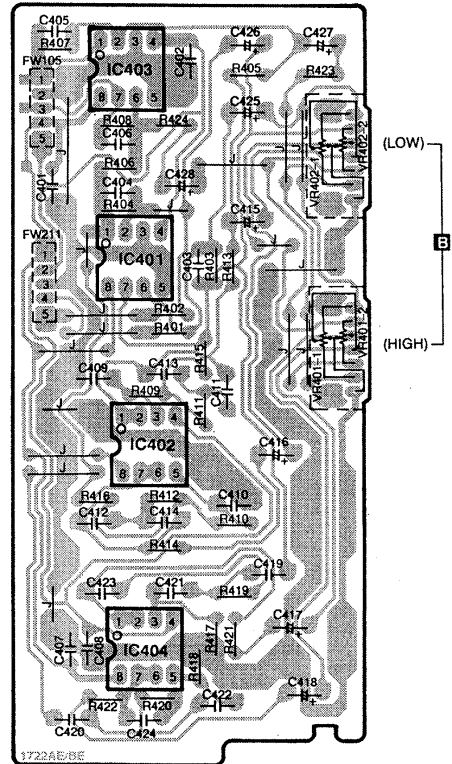

(REP2415B-M...[E, EB, GN]
 REP2415C-M...[PP]
 REP2415D-M...[GU])

O TRANSFORMER P.C.B.

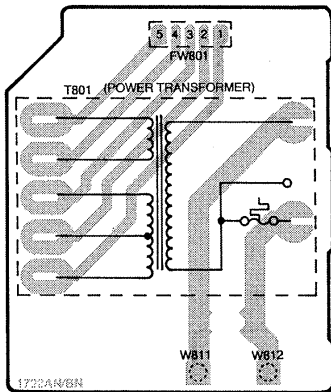

(REP2415B-M...[E, EB, GN]
 REP2415C-M...[PP]
 REP2415D-M...[GU])

P POWER SWITCH P.C.B.

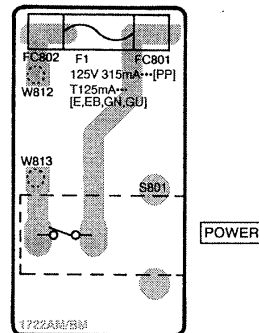

(REP2415B-M...[E, EB, GN]
 REP2415C-M...[PP]
 REP2415D-M...[GU])

N LED P.C.B.

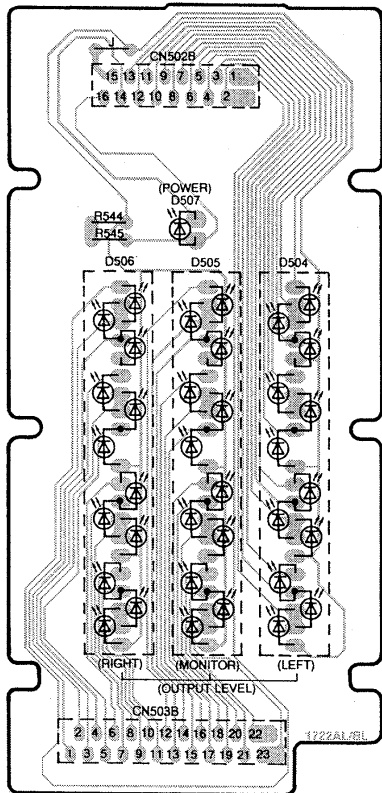

(REP2415B-M...[E, EB, GN])
 (REP2415C-M...[PP])
 (REP2415D-M...[GU])

J MIC P.C.B.

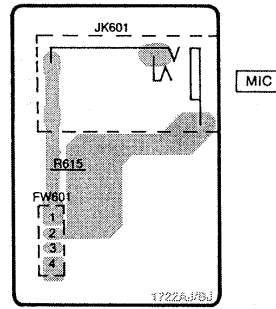

(REP2415B-M...[E, EB, GN])
 (REP2415C-M...[PP])
 (REP2415D-M...[GU])

Q HEADPHONES P.C.B.

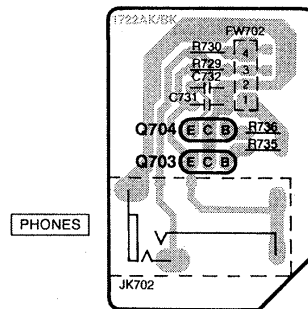

(REP2415B-M...[E, EB, GN])
 (REP2415C-M...[PP])
 (REP2415D-M...[GU])

R CHANNEL FADER (SPARE) P.C.B.

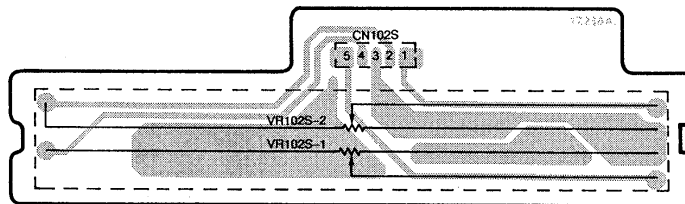

(REP2416A-S)

S CROSS FADER (SPARE) P.C.B.

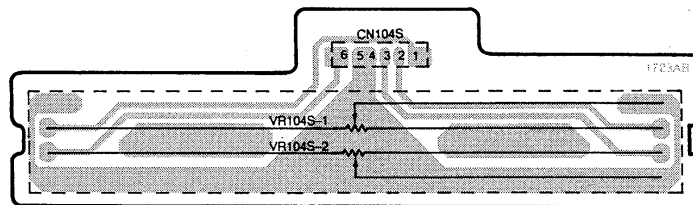

(REP2416A-S)

G CHANNEL FADER A P.C.B.

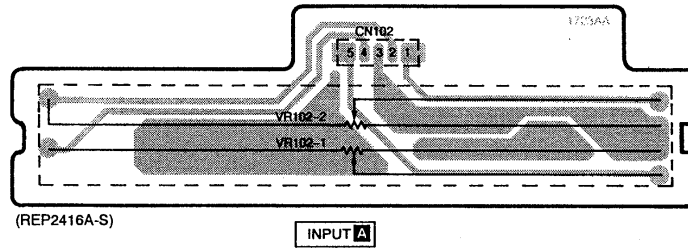

H CROSS FADER P.C.B.

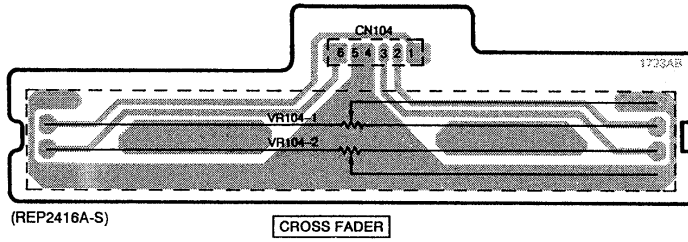

I CHANNEL FADER B P.C.B.

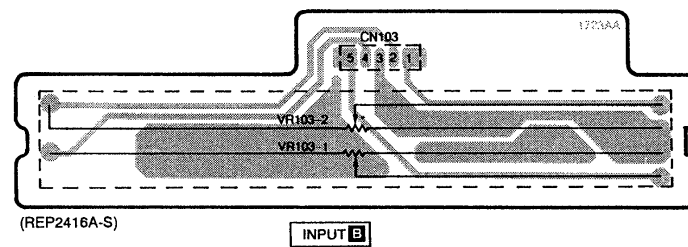

● Terminal guide of IC'S, transistors and diodes

<p>AN6558F UPC4570C</p>	<p>IR2432</p>	<p>M5F7812L M5F7815L</p>	<p>M5F7915L</p>	<p>UN4115TA</p>	<p>2SC3327ABTA 2SD2144STA</p>
<p>RL1N4003N02</p>	<p>MA165TA</p>	<p>LN850RPLS</p>	<p>GL112M9</p>	<p>MA4056MTA</p>	

Wiring Connection Diagram

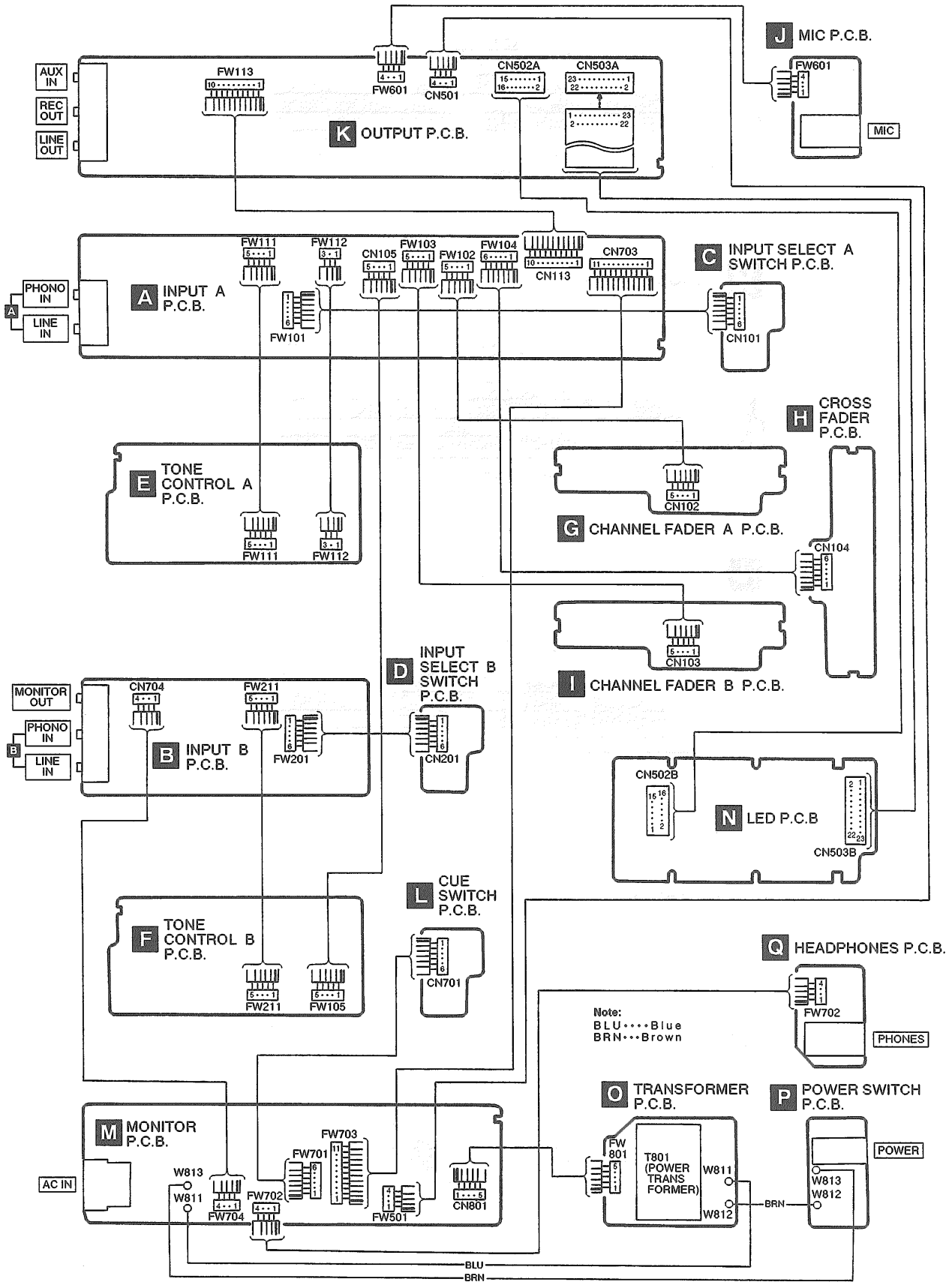

■ Replacement Parts List

Notes: *Important safety notice:

 Components identified by Δ mark have special characteristics important for safety.

Furthermore, special parts which have purposes of fire-retardant (resistors), high-quality sound (capacitors), low-noise (resistors), etc. are used.

When replacing any of components, be sure to use only manufacture's specified parts shown in the parts list.

*The parenthesized indications in the Remarks columns specify the areas. (Refer to the cover page for area.)

Parts without these indications can be used for all areas.

*The "(SF)" mark denotes the standard part.

*-<VRD>-: indicates parts that are supplied by Video Recorder Division.

Ref. No.	Part No.	Part Name & Description	Remarks	Ref. No.	Part No.	Part Name & Description	Remarks
		INTEGRATED CIRCUIT(S)		VR104S	EVBK4M20B15	VR, CROSS FADER	
						COIL(S)	
IC101	AN6558F	IC					
IC102-104	UPC4570C	IC		L1	SLQZ650MH49	COIL	Δ
IC201	AN6558F	IC				TRANSFORMER(S)	
IC202	UPC4570C	IC					
IC301-304	UPC4570C	IC		T801	RTP1U4B001-V	POWER TRANSFORMER	Δ (E, EB, GN, GU)
IC401-404	UPC4570C	IC		T801	RTP1U4C002-V	POWER TRANSFORMER	Δ (PP)
IC501-504	UPC4570C	IC				FUSE(S)	
IC505-507	IR2432	IC					
IC601	AN6558F	IC		F1	XBA2C012TB0S	FUSE	Δ (E, EB, GN, GU)
IC602	UPC4570C	IC		F1	XBA1C03NBAU	FUSE	Δ (PP)
IC701, 702	UPC4570C	IC				SWITCH(ES)	
IC801	M5F7815L	IC	Δ				
IC802	M5F7915L	IC	Δ				
IC803	M5F7812L	IC	Δ				
		TRANSISTOR(S)		S101	RST2B001-H	SW	
				S201	RST2B001-H	SW	
Q501-505	2SC3327ABTA	TRANSISTOR		S701	RST2B001-H	SW	
Q701-704	2SC3327ABTA	TRANSISTOR		S801	ESB8279V	SW	Δ
Q705	UN4115	TRANSISTOR				CONNECTOR(S)	
Q801, 802	2SD2144S	TRANSISTOR					
		DIODE(S)		CN101	RJS6T4ZA	SOCKET(6P)	
				CN102, 103	RJS5T4ZA	SOCKET(5P)	
D501-503	MA165	DIODE		CN104	RJS6T4ZA	SOCKET(6P)	
D504-506	GL112M9	LED		CN105	RJS5T7ZA	SOCKET(5P)	
D507	LN850RPLS	LED		CN113	RJS10T7ZA	SOCKET(10P)	
D801-809	RL1N4003N02	DIODE	Δ	CN201	RJS6T4ZA	SOCKET(6P)	
D810	MA4056MTA	DIODE	Δ	CN501	RJS4T7ZA	SOCKET(4P)	
		VARIABLE RESISTOR(S)		CN701	RJS6T4ZA	SOCKET(6P)	
				CN703	RJS11T7ZA	SOCKET(11P)	
VR101	EVJC20F03B24	VR, TRIM		CN704	RJS4T7ZA	SOCKET(4P)	
VR102, 103	EVBK3M20A15	VR, CHANNEL FADER		CN801	RJS5T7ZA	SOCKET(5P)	
VR104	EVBK4M20B15	VR, CROSS FADER		CN502A	RJS1A6716-Q	CONNECTOR(16P)	
VR201	EVJC20F03B24	VR, TRIM		CN503A	RJS1A6723-Q	CONNECTOR(23P)	
VR301, 302	EWCCU3FB7G54	VR, TONE		CN502B	RJS1A6216-1	CONNECTOR(16P)	
VR401, 402	EWCCU3FB7G54	VR, TONE		CN503B	RJS1A6223-1	CONNECTOR(23P)	
VR501	EVJC20F03V15	VR, MASTER		CN102S	RJS5T4ZA	SOCKET(5P)	
VR601	EVJ01BF03D54	VR, MIC LEVEL		CN104S	RJS6T4ZA	SOCKET(6P)	
VR602	EVJC20F03D54	VR, AUX LEVEL				FUSE HOLDER(S)	
VR701	EVJCAF7G15	VR, MONITOR BALANCE					
VR702	EVJC20FA7V15	VR, MONITOR LEVEL		FC801, 802	EYF52BC	FUSE HOLDER	
VR102S	EVBK3M20A15	VR, CHANNEL FADER					

Ref. No.	Part No.	Part Name & Description	Remarks	Ref. No.	Part No.	Part Name & Description	Remarks
		CABLE HOLDER(S)				JACK(S)	
FW101	RJS2A1306	CABLE HOLDER(6P)		JK101	SJF3067-2A	JACK	
FW102, 103	RJS2A1305	CABLE HOLDER(5P)		JK201	RJH2602A	JACK	
FW104	RJS2A1306	CABLE HOLDER(6P)		JK601	RJ63TA01	JACK	
FW113	RJS2A1310	CABLE HOLDER(10P)		JK602	RJH2602A	JACK	
FW201	RJS2A1306	CABLE HOLDER(6P)		JK702	RJ63TA01	JACK	
FW701	RJS2A1306	CABLE HOLDER(6P)		JK801	SJS9236	JACK	△ (E, EB, GN, GU)
FW703	RJS2A1311	CABLE HOLDER(11P)		JK801	SJSD16-1	JACK	△ (PP)
FW704	RJS2A1304	CABLE HOLDER(4P)					
FW801	RJS2A1305	CABLE HOLDER(5P)					

Ref. No.	Part No.	Part Name & Description	Remarks	Ref. No.	Part No.	Part Name & Description	Remarks
		CABINET AND CHASSIS		27	RMR1028-K	BOTTOM COVER	
1	RYP0712A-K	PANEL ASS'Y		28	RGR0249A-B	REAR PANEL	(E)
1-1	RMS0562	SCREW		28	RGR0249A-C	REAR PANEL	(EB)
1-2	RMS0564	BOSS		28	RGR0249A-D	REAR PANEL	(GN, GU)
2	RMN0203	P. C. B. HOLDER		28	RGR0249B-A	REAR PANEL	(PP)
3	RMN0412	HOLDER		29	RGQ0197-K	FRONT COVER	
4	RMQ0664	BRACKET, JACK		30	RGV0194-K	KNOB, FADER	
5	XTB3+8J	SCREW		31	RGW0258-K	KNOB, MASTER	
6	RMQ0663	BRACKET, SLIDE VR		32	RGW0257-K	KNOB, TRIM	
7	XYN3+C5S	SCREW		33	RMK0341	CHASSIS	(E, EB, GN, GU)
8	RMF0246	HIMELON A		33	RFKNDJ1200PP	CHASSIS ASS'Y	(PP)
9	RMN0408	BRACKET, P. TRANSFORMER		34	XTB3+6G	SCREW	
10	XTB4+8J	SCREW		35	RFKNDJ1200K	METER FRAME ASS'Y	
11	RGU0890-K	BUTTON, POWER		36	XYN3+C8S	SCREW	
12	RMR1029-K	BRACKET, POWER SW		37	SHR328	BINDER	
13	RHW1A001	SPRING WASHER		38	RWJ5703080SS	FLAT CABLE (3P/FW112)	
14	XNSS12	NUT		39	RWJ5705080SS	FLAT CABLE (5P/FW111, 211)	
15	RMV0126	BARRIER		40	RWJ5704180SS	FLAT CABLE (4P/FW601)	
16	REZ0947	FFC (16P)		41	RWJ5704130QQ	FLAT CABLE (4P/FW704)	
17	REZ0952	FFC (23P)		42	RWJ5704230SS	FLAT CABLE (4P/FW702)	
18	RMN0407	BRACKET, JACK		43	RWJ5705150QS	FLAT CABLE (5P/FW105)	
19	XTBS3+8JFZ1	SCREW		44	RWJ5705170QQ	FLAT CABLE (5P/FW103)	
20	XNS9	NUT		45	RWJ5706170QQ	FLAT CABLE (6P/FW104)	
21	RGV0195-N	KNOB, PHONO/LINE/CUE		46	RWJ5704100SS	FLAT CABLE (4P/J1)	
22	XXE2C3FT	SCREW		47	RWJ4305130QQ	FLAT CABLE (5P/FW102)	
23	RMF0247	HIMELON B		48	RWJ5705100QQ	FLAT CABLE (5P/FW801)	
24	XYN3+C6S	SCREW		49	RWJ5704200QS	FLAT CABLE (4P/FW501)	
25	RFKJDJ1200E	BOTTOM BOARD ASS'Y	(E, EB, GN)	50	RWJ5706100QQ	FLAT CABLE (6P/FW101, 201, 701)	
25	RFKJDJ1200GU	BOTTOM BOARD ASS'Y	(GU)	51	RWJ5710220QQ	FLAT CABLE (10P/FW113)	
25	RFKJDJ1200PP	BOTTOM BOARD ASS'Y	(PP)	52	RWJ5711370QQ	FLAT CABLE (11P/FW703)	
26	RKA0053-A	FOOT		53	XYN3+C6S	SCREW	(GU)

Cabinet Parts Location

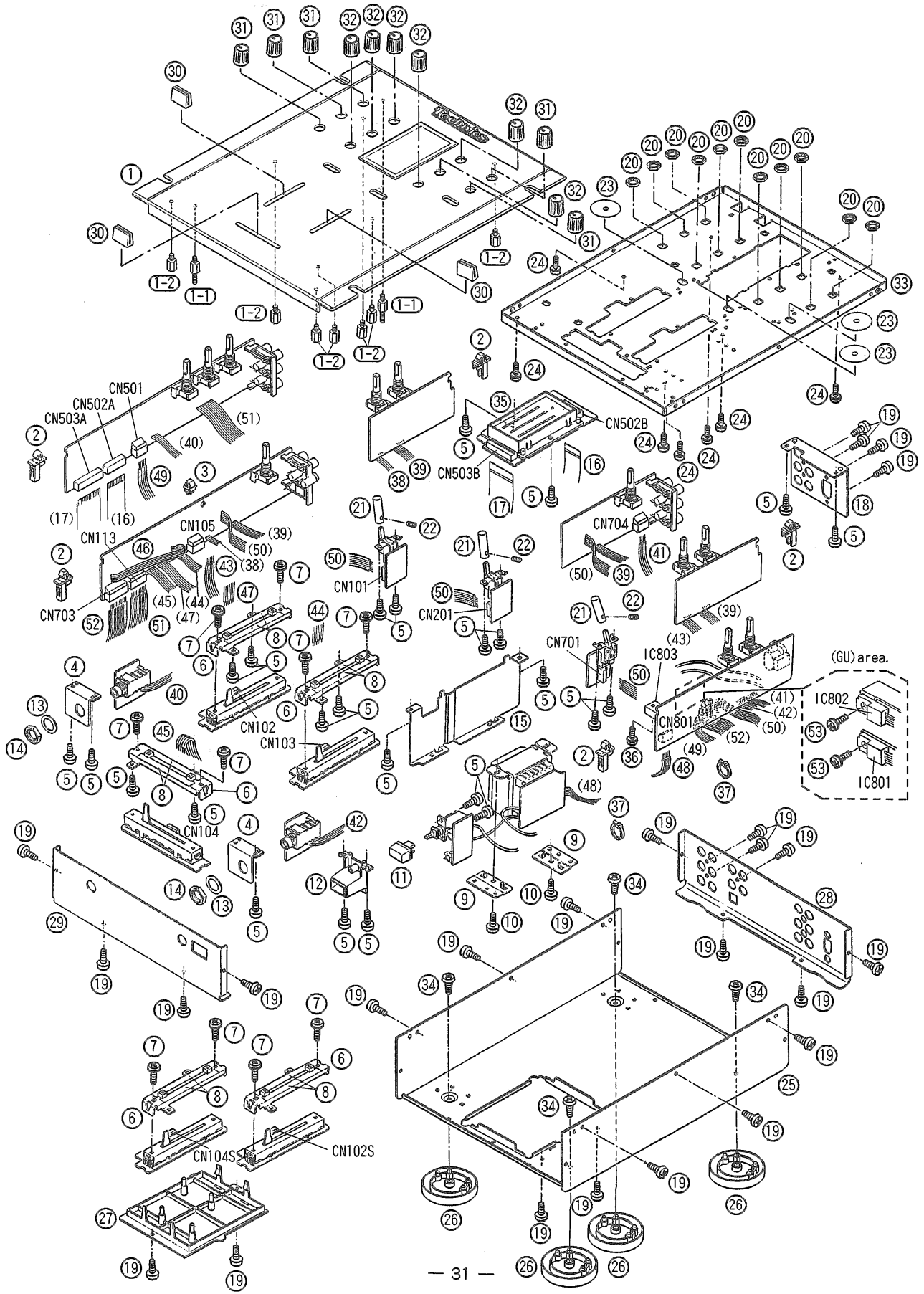

Notes : * Capacity values are in microfarads (μF) unless specified otherwise, P=Pico-farads (pF) F=Farads (F)
 * Resistance values are in ohms, unless specified otherwise, 1K=1,000(OHM) , 1M=1,000k(OHM)

Ref. No.	Part No.	Values & Remarks	Ref. No.	Part No.	Values & Remarks	Ref. No.	Part No.	Values & Remarks
		RESISTORS	R419, 420	ERDS2TJ473	1/4W 47K			CAPACITORS
			R421, 422	ERDS2TJ152	1/4W 1.5K			
			R423, 424	ERDS2TJ472	1/4W 4.7K	C101, 102	ECBT1H181KB5	50V 180P
R101, 102	ERDS2TJ102	1/4W 1K	R501-504	ERDS2TJ472	1/4W 4.7K	C103, 104	RCE1HKA3R3BG	50V 3.3U
R103, 104	ERDS2TJ224	1/4W 220K	R505, 506	ERDS2TJ103	1/4W 10K	C105, 106	ECEA1CKA330B	16V 33U
R105, 106	ERDS2TJ101	1/4W 100	R511, 512	ERDS2TJ563	1/4W 56K	C107, 108	ECBT1E223ZF	25V 0.022U
R107, 108	ERDS2TJ563	1/4W 56K	R513, 514	ERDS2TJ471	1/4W 470	C109, 110	ECBT1H391KB5	50V 390P
R109, 110	ERDS2TJ271	1/4W 270	R515, 516	ERDS2TJ183	1/4W 18K	C111, 112	ECQB1H562JF3	50V 5600P
R111, 112	ERDS2TJ680	1/4W 68	R517, 518	ERDS2TJ563	1/4W 56K	C113, 114	ECQB1H223JF3	50V 0.022U
R113, 114	ERDS2TJ123	1/4W 12K	R519, 520	ERDS2TJ100	1/4W 10	C115, 116	ECBT1C472KR5	16V 4700P
R115, 116	ERDS2TJ184	1/4W 180K	R521, 522	ERDS2TJ222	1/4W 2.2K	C117, 118	RCE1CKA100BG	16V 10U
R117, 118	ERDS2TJ102	1/4W 1K	R523, 524	ERDS2TJ561	1/4W 560	C119, 120	ECEA1HKA010B	50V 1U
R119, 120	ERDS2TJ563	1/4W 56K	R525, 526	ERDS2TJ102	1/4W 1K	C121, 122	ECBT1H220J5	50V 22P
R121-124	ERDS2TJ103	1/4W 10K	R531, 532	ERDS2TJ683	1/4W 68K	C123, 124	ECBT1H181KB5	50V 180P
R125, 126	ERDS2TJ224	1/4W 220K	R533-535	ERDS2TJ333	1/4W 33K	C125, 126	RCE1HKA3R3BG	50V 3.3U
R127, 128	ERDS2TJ102	1/4W 1K	R536	ERDS2TJ153	1/4W 15K	C127	ECBT1E223ZF	25V 0.022U
R129, 130	ERDS2TJ563	1/4W 56K	R537-539	ERDS2TJ103	1/4W 10K	C131-134	ECEA1HKA010B	50V 1U
R141-144	ERDS2TJ474	1/4W 470K	R541-543	ERDS2TJ823	1/4W 82K	C135, 136	ECBT1E223ZF	25V 0.022U
R145-152	ERDS2TJ472	1/4W 4.7K	R544, 545	ERDS2TJ681	1/4W 680	C137, 138	ECBT1H101KB5	50V 100P
R160	ERDS2TJ100	1/4W 10	R546	ERDS2TJ102	1/4W 1K	C139-142	ECEA1HKA010B	50V 1U
R201, 202	ERDS2TJ102	1/4W 1K	R547, 548	ERDS2TJ333	1/4W 33K	C143, 144	ECBT1E223ZF	25V 0.022U
R203, 204	ERDS2TJ224	1/4W 220K	R601	ERDS2TJ471	1/4W 470	C145, 146	ECBT1H101KB5	50V 100P
R205, 206	ERDS2TJ101	1/4W 100	R602	ERDS2TJ103	1/4W 10K	C151, 152	RCE1CKA100BG	16V 10U
R207, 208	ERDS2TJ563	1/4W 56K	R603	ERDS2TJ272	1/4W 2.7K	C201, 202	ECBT1H181KB5	50V 180P
R209, 210	ERDS2TJ271	1/4W 270	R604	ERDS2TJ223	1/4W 22K	C203, 204	RCE1HKA3R3BG	50V 3.3U
R211, 212	ERDS2TJ680	1/4W 68	R605	ERDS2TJ273	1/4W 27K	C205, 206	ECEA1CKA330B	16V 33U
R213, 214	ERDS2TJ123	1/4W 12K	R606, 607	ERDS2TJ104	1/4W 100K	C207, 208	ECBT1E223ZF	25V 0.022U
R215, 216	ERDS2TJ184	1/4W 180K	R611, 612	ERDS2TJ102	1/4W 1K	C209, 210	ECBT1H391KB5	50V 390P
R217, 218	ERDS2TJ102	1/4W 1K	R613, 614	ERDS2TJ563	1/4W 56K	C211, 212	ECQB1H562JF3	50V 5600P
R219, 220	ERDS2TJ563	1/4W 56K	R615	ERDS2TJ102	1/4W 1K	C213, 214	ECQB1H223JF3	50V 0.022U
R221-224	ERDS2TJ103	1/4W 10K	R707-712	ERDS2TJ103	1/4W 10K	C215, 216	ECBT1C472KR5	16V 4700P
R225, 226	ERDS2TJ224	1/4W 220K	R713, 714	ERDS2TJ223	1/4W 22K	C217, 218	RCE1CKA100BG	16V 10U
R227, 228	ERDS2TJ102	1/4W 1K	R715, 716	ERDS2TJ103	1/4W 10K	C219, 220	ECEA1HKA010B	50V 1U
R229, 230	ERDS2TJ563	1/4W 56K	R719, 720	ERDS2TJ563	1/4W 56K	C221, 222	ECBT1H220J5	50V 22P
R301-308	ERDS2TJ223	1/4W 22K	R721, 722	ERDS2TJ471	1/4W 470	C223, 224	ECBT1H181KB5	50V 180P
R309, 310	ERDS2TJ563	1/4W 56K	R723, 724	ERDS2TJ562	1/4W 5.6K	C225, 226	RCE1HKA3R3BG	50V 3.3U
R311, 312	ERDS2TJ183	1/4W 18K	R725, 726	ERDS2TJ563	1/4W 56K	C227	ECBT1E223ZF	25V 0.022U
R313, 314	ERDS2TJ152	1/4W 1.5K	R729, 730	ERDS2TJ101	1/4W 100	C251, 252	RCE1CKA100BG	16V 10U
R315, 316	ERDS2TJ563	1/4W 56K	R731	ERDS2TJ224	1/4W 220K	C301, 302	ECBT1E223ZF	25V 0.022U
R317, 318	ERDS2TJ104	1/4W 100K	R732	ERDS2TJ471	1/4W 470	C303-306	ECBT1H330J5	50V 33P
R319, 320	ERDS2TJ473	1/4W 47K	R733-736	ERDS2TJ102	1/4W 1K	C307, 308	ECBT1E223ZF	25V 0.022U
R321, 322	ERDS2TJ152	1/4W 1.5K	R739, 740	ERDS2TJ471	1/4W 470	C309, 310	ECQB1H153JF3	50V 0.015U
R323, 324	ERDS2TJ472	1/4W 4.7K	R741, 742	ERDS2TJ222	1/4W 2.2K	C311, 312	ECQB1H273JF3	50V 0.027U
R401-408	ERDS2TJ223	1/4W 22K	R801	ERDS2TJ274	1/4W 270K	C313, 314	ECQB1H273JF3	50V 2700P
R409, 410	ERDS2TJ563	1/4W 56K	R802	ERDS2TJ104	1/4W 100K	C315-318	ECA1CM221B	16V 220U
R411, 412	ERDS2TJ183	1/4W 18K	R803	ERDS2TJ473	1/4W 47K	C319-322	ECQB1H152JF3	50V 1500P
R413, 414	ERDS2TJ152	1/4W 1.5K	R804	ERDS1FJ152	1/2W 1.5K Δ	C323, 324	ECQB1H682JF3	50V 6800P
R415, 416	ERDS2TJ563	1/4W 56K	R805	ERDS2TJ103	1/4W 10K	C325, 326	ECEA1CKA101B	16V 100U
R417, 418	ERDS2TJ104	1/4W 100K				C327, 328	ECA1CM221B	16V 220U

Ref. No.	Part No.	Values & Remarks	Ref. No.	Part No.	Values & Remarks			
C401, 402	ECBT1E223ZF	25V 0.022U	C737, 738	RCE1CKA100BG	16V 10U			
C403-406	ECBT1H330J5	50V 33P	C801, 802	ECA1EM101B	25V 100U			
C407, 408	ECBT1E223ZF	25V 0.022U	C803, 804	ECBT1E223ZF	25V 0.022U			
C409, 410	ECQB1H153JF3	50V 0.015U	C805, 806	ECA1EM102B	25V 1000U Δ			
C411, 412	ECQB1H273JF3	50V 0.027U	C807	ECKR2H682PE	500V 6800P			
C413, 414	ECQB1H272JF3	50V 2700P	C808	ECEA1HKAR33B	50V 0.33U			
C415-418	ECA1CM221B	16V 220U	C809	ECEA0JKA101B	6.3V 100U			
C419-422	ECQB1H152JF3	50V 1500P	C810	ECEA1CKA101B	16V 100U			
C423, 424	ECQB1H682JF3	50V 6800P	C811	ECBT1E223ZF	25V 0.022U			
C425, 426	ECEA1CKA101B	16V 100U	C812	ECA1EM102B	25V 1000U Δ			
C427, 428	ECA1CM221B	16V 220U	C813	ECKR1H103ZF5	50V 0.01U			
C503, 504	ECBT1E223ZF	25V 0.022U						
C505, 506	ECBT1H330J5	50V 33P						
C511, 512	RCE1HKA3R3BG	50V 3.3U						
C513, 514	ECBT1H101KB5	50V 100P						
C515, 516	ECBT1E223ZF	25V 0.022U						
C517, 518	RCE1CKA100BG	16V 10U						
C519, 520	ECBT1H101KB5	50V 100P						
C521, 522	ECBT1H220J5	50V 22P						
C523-525	RCE1HKA3R3BG	50V 3.3U						
C526	ECEA1CKA101B	16V 100U						
C527	ECEA0JKA101B	6.3V 100U						
C529-533	RCE1CKA100BG	16V 10U						
C601	ECBT1H181KB5	50V 180P						
C602	ECQV1H154JM3	50V 0.15U						
C603	ECEA1HKA010B	50V 1U						
C604	ECBT1E223ZF	25V 0.022U						
C605	ECBT1H101KB5	50V 100P						
C606	ECBT1H100J5	50V 10P						
C607	ECBT1E223ZF	25V 0.022U						
C608, 609	ECBT1H101KB5	50V 100P						
C610	ECEA1HKA010B	50V 1U						
C611	ECBT1H100J5	50V 10P						
C612	ECEA1HKA010B	50V 1U						
C615, 616	ECBT1H181KB5	50V 180P						
C617, 618	RCE1HKA3R3BG	50V 3.3U						
C619-622	ECBT1H101KB5	50V 100P						
C625, 626	ECBT1E223ZF	25V 0.022U						
C630	ECBT1E223ZF	25V 0.022U						
C631	ECEA1HKA010B	50V 1U						
C701-704	RCE1CKA100BG	16V 10U						
C709-712	RCE1CKA100BG	16V 10U						
C713, 714	ECBT1H330J5	50V 33P						
C715, 716	RCE1CKA100BG	16V 10U						
C717, 718	RCE1HKA3R3BG	50V 3.3U						
C719, 720	ECBT1H101KB5	50V 100P						
C721, 722	RCE1CKA100BG	16V 10U						
C723, 724	ECBT1H101KB5	50V 100P						
C725, 726	ECBT1H220JC5	50V 22P						
C730	ECBT1E223ZF	25V 0.022U						
C731, 732	ECBT1H473ZF5	50V 0.047U						
C735, 736	ECBT1H391KB5	50V 390P						

■ PACKAGING

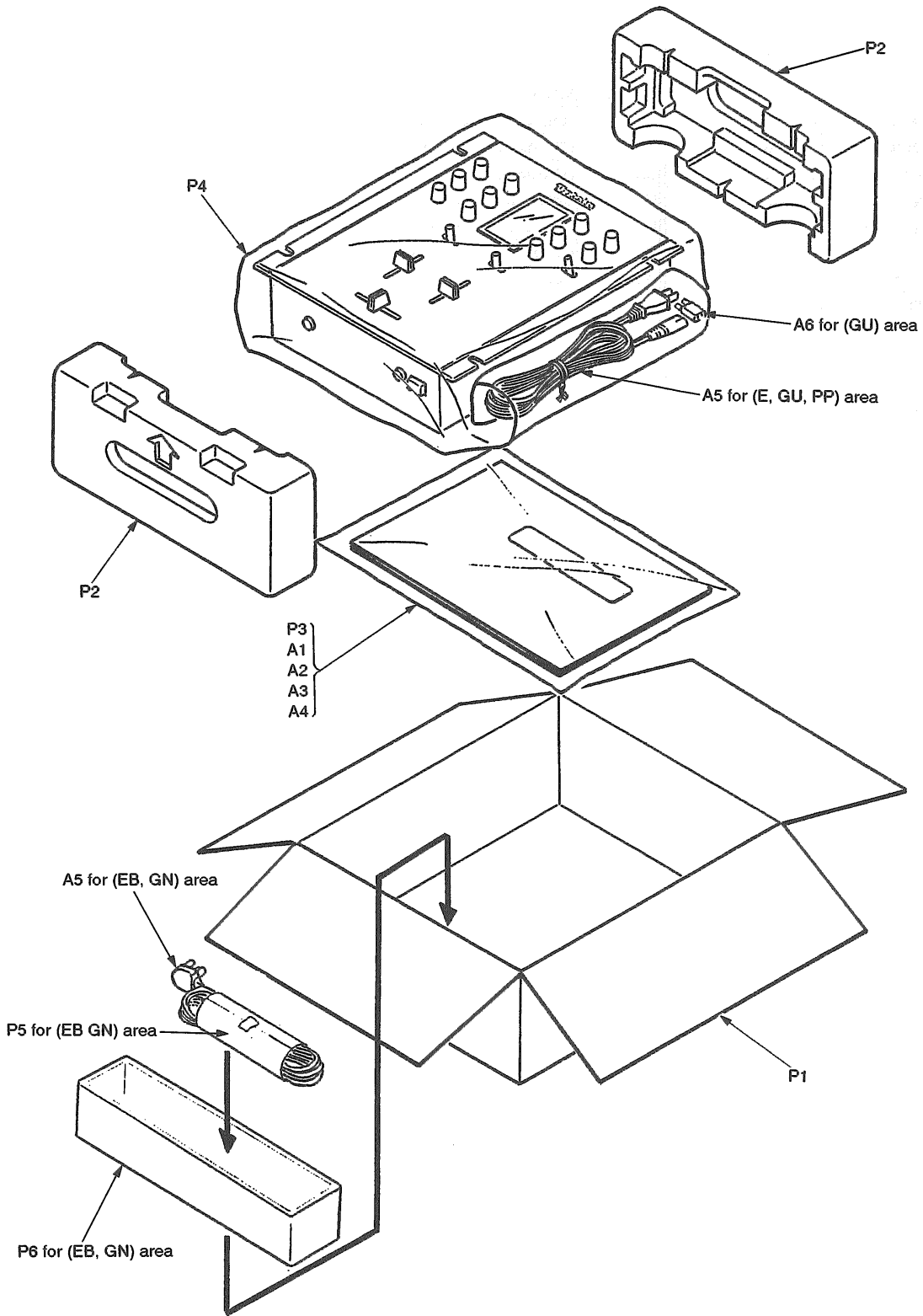

Ref. No.	Part No.	Part Name & Description	Remarks				
		PACKING MATERIAL					
P1	RPG3172	PACKING CASE	(E, GU)				
P1	RPG3357	PACKING CASE	(EB, GN)				
P1	RPG3171	PACKING CASE	(PP)				
P2	RPN1007	CUSHION					
P3	XZB25X34C03X	POLYETHYLENE BAG					
P4	SPP756	PROTECTION BAG					
P5	RPH0032	PROTECTION SHEET	(EB, GN)				
P6	RPQ0708	SPACER	(EB, GN)				
		ACCESSORIES					
A1	RQT3640-E	INSTRUCTION MANNUAL	(E) <IA>				
A1	RQT3641-D	INSTRUCTION MANNUAL	(E) <IB>				
A1	RQT3642-B	INSTRUCTION MANNUAL	(EB, GN) <IC>				
A1	RQT3643-G	INSTRUCTION MANNUAL	(GU) <ID>				
A1	RQT3639-Y	INSTRUCTION MANNUAL	(PP) <IE>				
A2	RQCA0512	SUB MANNUAL A					
A3	RQCA0534	SUB MANNUAL B					
A4	RFE0032	STICKER					
A5	RJA0019-2K	AC POWER CORD	△(SF) (E, GU)				
A5	VJA0733	AC POWER CORD	△(SF) (EB) <VRD>				
A5	RJA0035-K	AC POWER CORD	△(GN)				
A5	SJA172	AC POWER CORD	△(SF) (PP)				
A6	SJP5213-2	POWER PLUG ADAPTOR	△(GU)				
		SLIDE VOLUME KIT					
K1	RFKVHJ1200A	CROSS FADER KIT					
K2	RFKVHJ1200B	CHANNEL FADER KIT					

Note: The "<IA>, <IB>, <IC>, <ID>," marks in Remarks indicate language of instruction manual.

<IA>: English, Spanish, Dutch, Swedish	<IB>: German, Italian, French, Russian
<IC>: English	<ID>: English, Spanish, Arabic, Chinese
<IE>: English, French	